

# METHODOLOGICAL PROPOSAL

## An accessibility analysis in building and construction projects

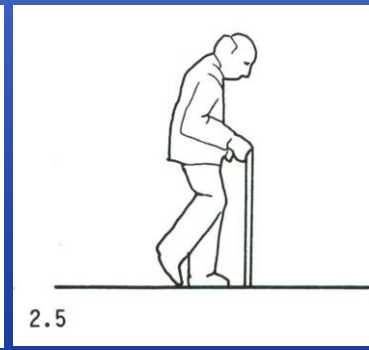
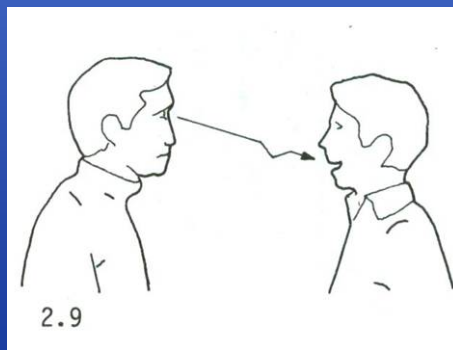
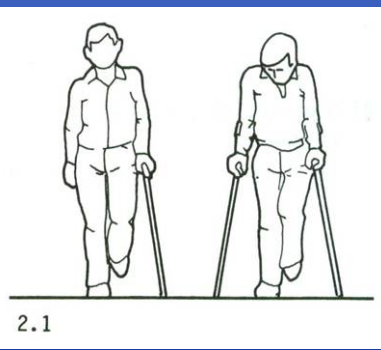

# 1.-A general reflection on ...

People's relations with their physical environments:

- What kinds of problems arise?
- What alternatives does architecture offer

# 2.-Boundaries based on ...

User types:

- walkers, wheel-chair users, sensory handicaps

Types of difficulties:

- manoeuvring, changing levels, reaching, controlling

Accessibility level:

- adapted, practicable, convertible

# 3.-Precision in ...

Reference parameters

# 4.-Examples of application ...

Old-age people's homes : "Trinitat" and "Llar Ancianitat"

# 5.-Appendix: Technologies for accessibility

"Active" technologies in improving personal autonomy at home

# Approach

Activity

Difficulty

M  
O  
V  
E  
M  
E  
N  
T

Horizontal → Manoeuvring

Vertical → Changing level

Route →

U  
S  
E

Preparation → Reaching

Performance → Controlling

Details →

# Alternative

Specified

which will be

affects

1.-Level or sloping gently.  
2.-As short as possible.  
3.-Passage range clear of obstacles  
4.-Secure supporting and guiding elements.

1.- Idea  
  
or  
2.- Choice of place

1.-Action also possible seated.  
2.-Remaining at place throughout  
3.-Doing without fine coordination  
4.-Doing without a basic sense: vision/hearing.

1.-Choice of materials  
  
or  
2.- Their location

# 1.-A general reflection on ...

People's relations with their physical environments:

- What kinds of problems arise?
- What alternatives does architecture offer

# 2.-Boundaries based on ...

User types:

- walkers, wheel-chair users, sensory handicaps

Types of difficulties:

- manoeuvring, changing levels, reaching, controlling

Accessibility level:

- adapted, practicable, convertible

# 3.-Precision in ...

Reference parameters

# 4.-Examples of application ...

Old-age people's homes : "Trinitat" and "Llar Ancianitat"

# 5.-Appendix: Technologies for accessibility

"Active" technologies in improving personal autonomy at home

# User types

## a) Walkers

People carrying out movements (displacements) on their own with difficulty, and with or without technical aids.

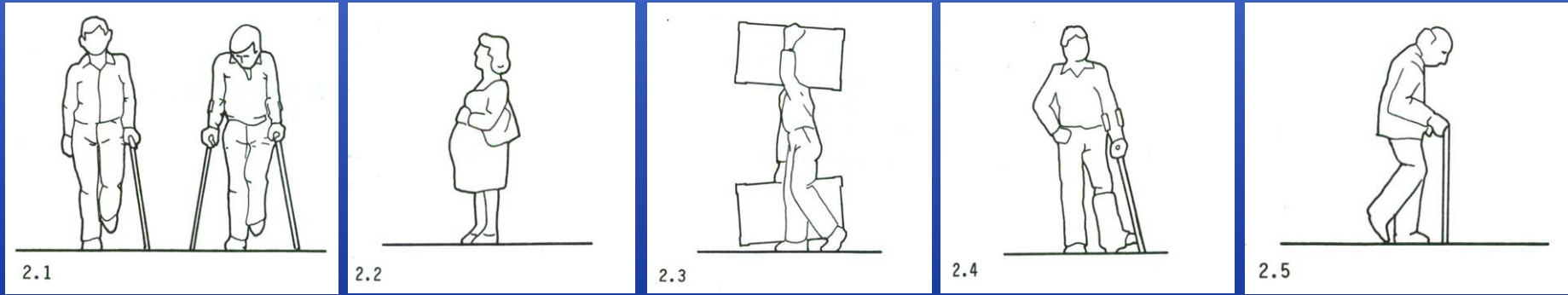

## a) Walkers ...

### MOVEMENT DIFFICULTIES

- 1.- Difficulty from strength- and balance-related problems in negotiating steep slopes, stairs and abrupt changes in level.
- 2.- Difficulty in passing through narrow spaces.
- 3.- Difficulty in travelling long stretches without resting.
- 4.- Greater danger of falling over from tripping or from feet or walking stick slipping.

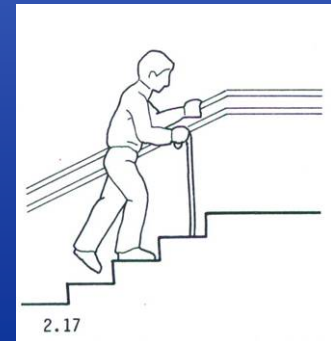

## a) Walkers ...

### USE DIFFICULTIES

- 1.- Difficulty in opening and closing doors, especially when they have return mechanisms.
- 2.- Difficulty in maintaining balance.
- 3.- Difficulty in sitting down and getting up.
- 4.- Difficulty in activating mechanisms requiring use of both hands at the same time.
- 5.- Difficulty in reaching objects.



# User types

## b) Wheel-chair users

People requiring wheel-chairs to carry out their movements, whether on their own or with third-party assistance.

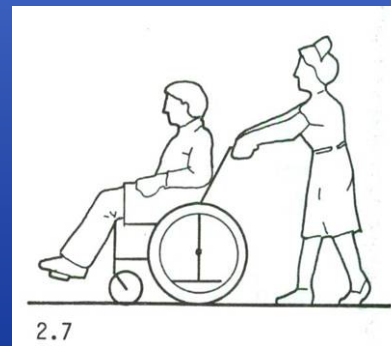



## b) Wheel-chair users ...

### MOVEMENT DIFFICULTIES

- 1.- Impossible to negotiate sudden changes in level, stairs and steep slopes.
- 2.- Danger of overturning (on steps, crossbeams, etc.).
- 3.- Impossible to pass through narrow spaces.
- 4.- Need for wide spaces for turning, opening doors, etc.

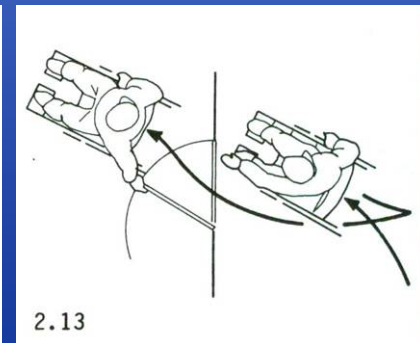
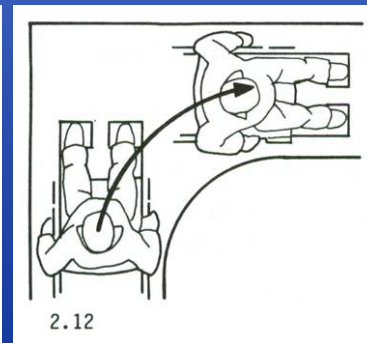
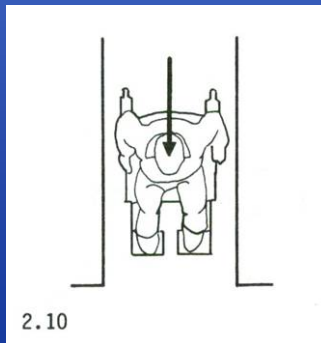
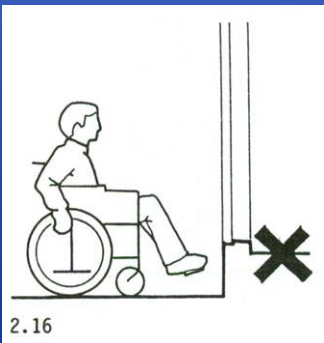

## b) Wheel-chair users ...

### USE DIFFICULTIES

- 1.- Limited in their possibilities of reaching objects.
- 2.- Limited in their areas of vision.
- 3.- Difficulties because of the obstacle their own legs pose.
- 4.- Problems of compatibility between wheel-chairs and other elements of furniture and fittings.

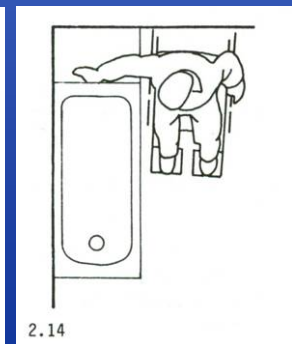
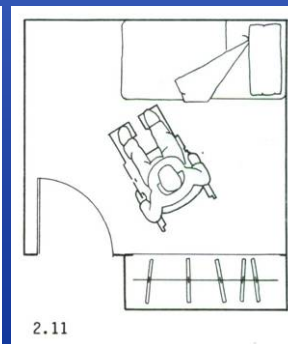

# User types

## c) Sensory handicaps

People who have sensory difficulties due to limitations in their sensory capacities, chiefly auditory and visual.

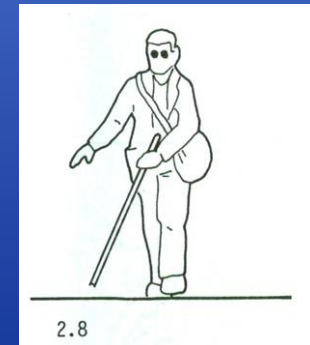
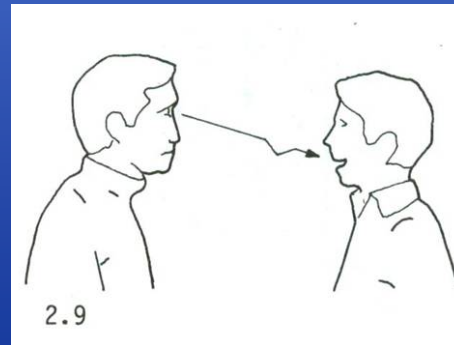

## c) Sensory handicaps

- VISUAL

### MOVEMENT DIFFICULTIES

- 1.- Detecting obstacles (changes in level, projecting elements, holes, etc.).
- 2.- Establishing directions and keeping to routes.

### USE DIFFICULTIES

- 1.- Getting graphic information (Written documents, graphic images, colours, etc.).
- 2.- Locating multiple objects (push buttons, handles, control elements in general, etc.).



## c) Sensory handicaps

- AUDITORY

- 1.- Getting information from acoustic signals (voice, alarms, bells, etc.).
- 2.- Limited capacity for relating to and making exchanges with other people. Feelings of isolation regarding the environment.

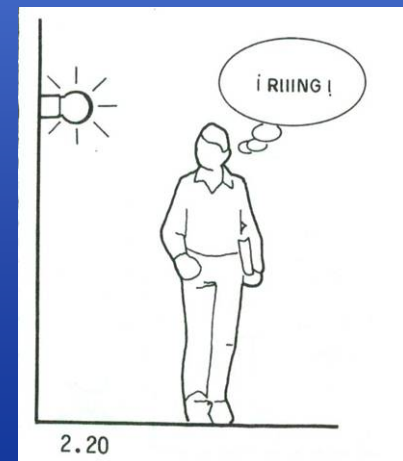

# Types of difficulties

- DIFFICULTY IN MANOEUVRING. Manoeuvre categories

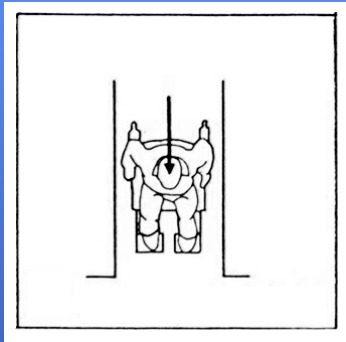

straight-line

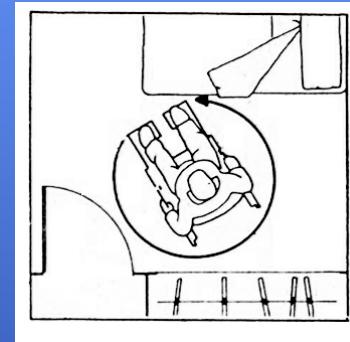

rotating

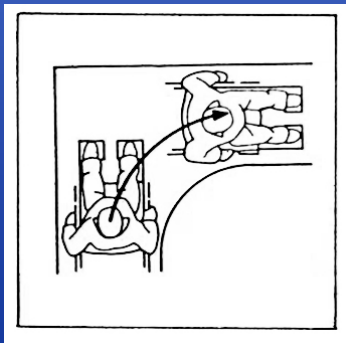

turning

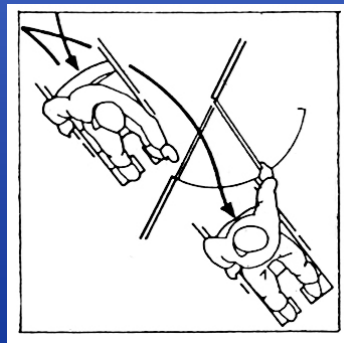

doorway crossing

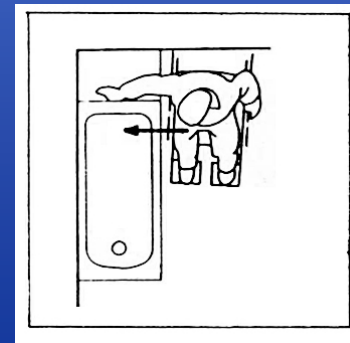

transferring

# Types of difficulties

- DIFFICULTY IN NEGOTIATING CHANGES IN LEVEL.  
Categories of changes in level

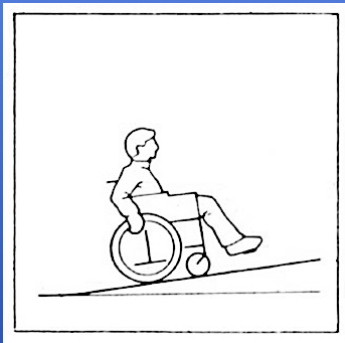

continuous

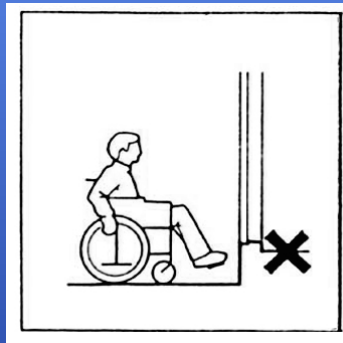

abrupt

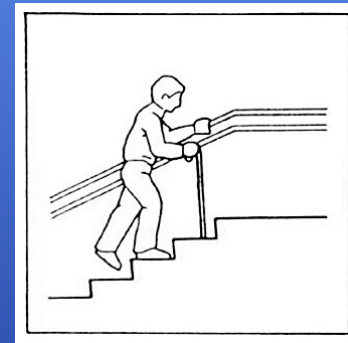

large

# Types of difficulties

- DIFFICULTY IN REACHING. Reaching categories



manual

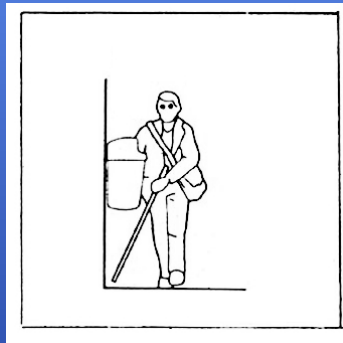

visual

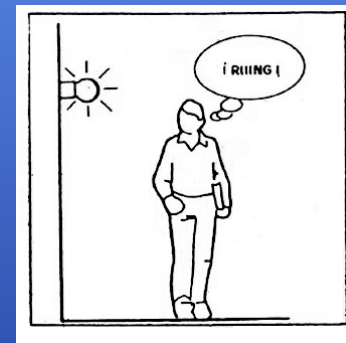

auditory



# Types of difficulties

- DIFFICULTY IN CONTROLLING. Control categories

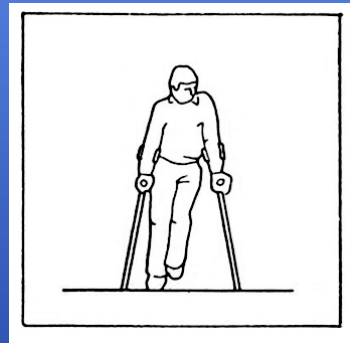

balance

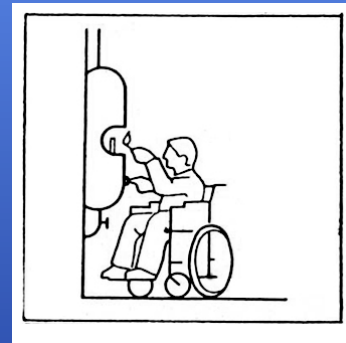

handling

# 1.-A general reflection on ...

People's relations with their physical environments:

- What kinds of problems arise?
- What alternatives does architecture offer

# 2.-Boundaries based on ...

User types:

- walkers, wheel-chair users, sensory handicaps

Types of difficulties:

- manoeuvring, changing levels, reaching, controlling

Accessibility level:

- adapted, practicable, convertible

# 3.-Precision in ...

Reference parameters

# 4.-Examples of application ...







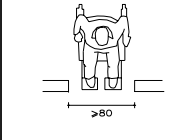
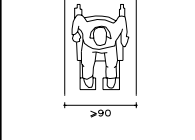
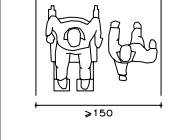

Old-age people's homes : "Trinitat" and "Llar Ancianitat"

# 5.-Appendix: Technologies for accessibility

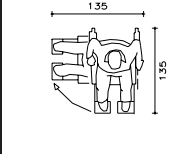
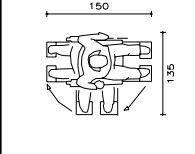
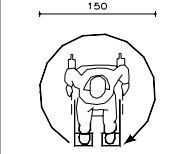
"Active" technologies in improving personal autonomy at home

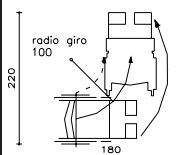
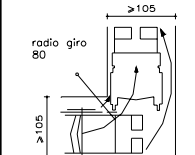
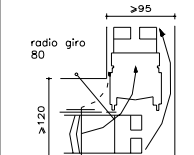

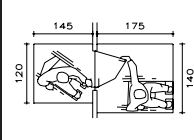
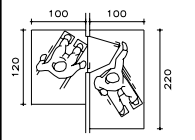

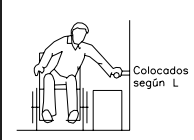
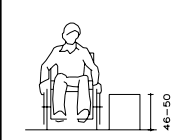
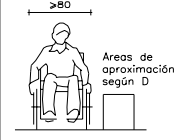

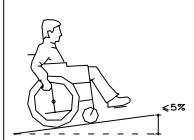
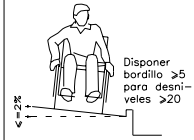

# DIFICULTAD DE MANIOBRA

PARAMETROS DE REFERENCIA

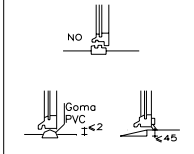
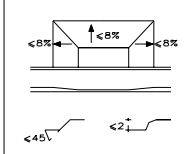
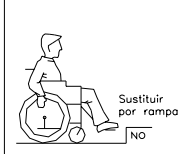
A		OBSTACULO AISLADO A.1	CIRCULACION A.2	DOBLE CIRCULACION A.3
				
		EN LINEA RECTA		
B		90 GRADOS B.1	180 GRADOS B.2	360 GRADOS B.3
				
		ROTACION		
C		LUGAR ABIERTO C.1	PASILLO ANCHO CONSTANTE C.2	PASILLO ANCHO VARIABLE C.3
				
		GIRO		
D		APROXIMACION FRONTAL D.1	APROXIMACION LATERAL D.2	
				
		PASAR PUERTA		
E		1ª CONDICION Barra al alcance E.1	2ª CONDICION Nivel asiento E.2	3ª CONDICION Espacio de aproximacion E.3
				
		TRANSFERENCIA		

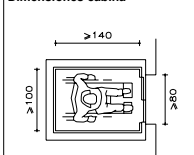
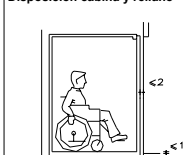

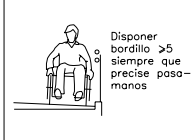

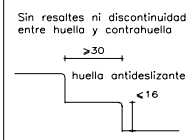

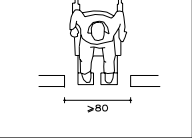
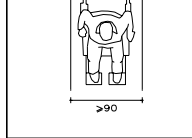
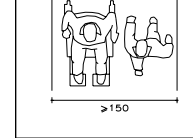

# DIFICULTAD DE SALVAR DESNIVELES

PARAMETROS DE REFERENCIA

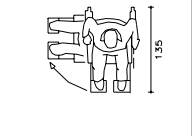
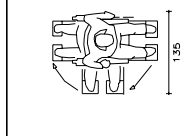
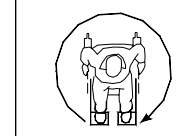
I		ITINERARIO En pendiente longitudinal I.1	ITINERARIO En pendiente transversal I.2	ITINERARIO EN PENDIENTE I.3 Dimensiones
				Anchura según A +10% Áreas de maniobra giro 90° según C +10% rotación según B +10% Área para franquear puerta según D en llano
		CONTINUO		
J		UMBRAL J.1	PASO DE PEATONES J.2	AISLADO J.3
				
		BRUSCO		
K		ASCENSOR Dimensiones cabina K.1	ASCENSOR Disposición cabina y rellano K.2	ASCENSOR Otras condiciones K.3
				Rellano espera dimensiones según D Botonera colocación según F sobre plano vertical Pasamanos interior cabina disponer según L
		GRAN DESNIVEL		
		RAMPA Pendiente longitudinal, útil para desniveles = 3m K.4	RAMPA Pendiente transversal K.5	RAMPA Otras condiciones K.6
				Anchura según A+10% Áreas de maniobra según B, C y D en llano Rellanos intermedios longitud en la dirección de circulación >150 Pasamanos disponer en rampa con pendiente >6% según L Pavimento antiderrapante
		ESCALERA Peldaños K.7	ESCALERA Otras condiciones K.8	
			Anchura de paso >90 Pasamanos según L Número máximo de escalones sin rellano intermedio 12	

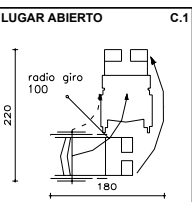
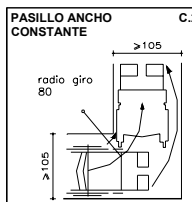
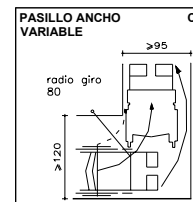

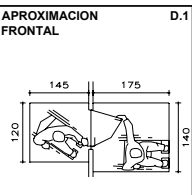
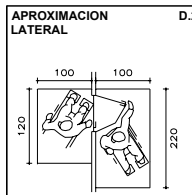

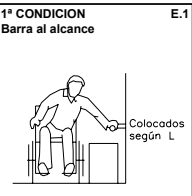
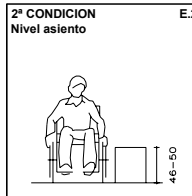
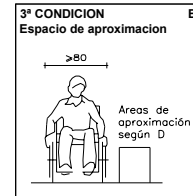

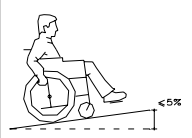
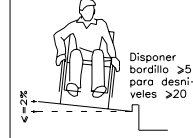

# DIFICULTAD DE MANIOBRA

PARAMETROS DE REFERENCIA

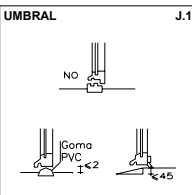
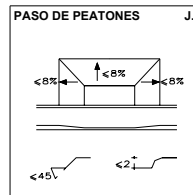
A		OBSTACULO AISLADO A.1	CIRCULACION A.2	DOBLE CIRCULACION A.3
				
		EN LINEA RECTA		
B		90 GRADOS B.1	180 GRADOS B.2	360 GRADOS B.3
				
		ROTACION		
C		LUGAR ABIERTO C.1	PASILLO ANCHO CONSTANTE C.2	PASILLO ANCHO VARIABLE C.3
				
		GIRO		
D		APROXIMACION FRONTAL D.1	APROXIMACION LATERAL D.2	
				
		PASAR PUERTA		
E		1ª CONDICION Barra al alcance E.1	2ª CONDICION Nivel asiento E.2	3ª CONDICION Espacio de aproximacion E.3
				
		TRANSFERENCIA		

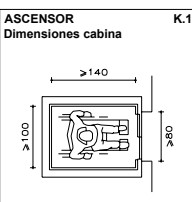

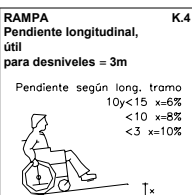
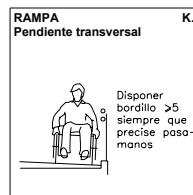

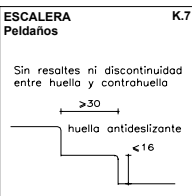
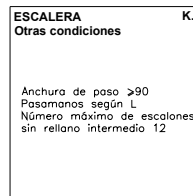



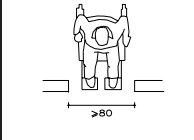
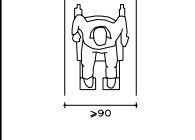
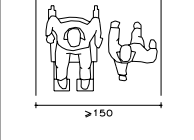

# DIFICULTAD DE SALVAR DESNIVELES

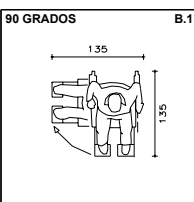
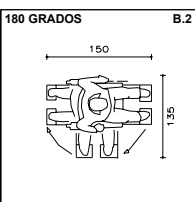
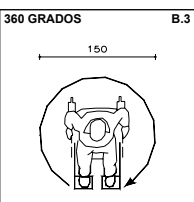
PARAMETROS DE REFERENCIA

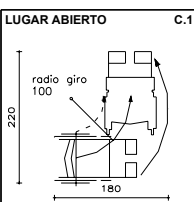
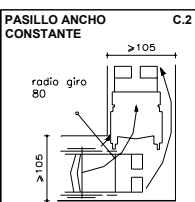
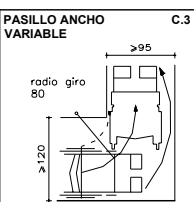
I		ITINERARIO En pendiente longitudinal I.1	ITINERARIO En pendiente transversal I.2	ITINERARIO EN PENDIENTE I.3 Dimensiones
				Anchura según A +10% Areas de maniobra giro 90° según C +10% rotación según B +10% Area para franquear puerta según D en llano
		CONTINUO		
J		UMBRAL J.1	PASO DE PEATONES J.2	AISLADO J.3
				
		BRUSCO		
K		ASCENSOR Dimensiones cabina K.1	ASCENSOR Disposición cabina y rellano K.2	ASCENSOR Otras condiciones K.3
				Rellano espera dimensiones según D Botonera colocación según F sobre plano vertical Pasamanos interior cabina disponer según L
		GRAN DESNIVEL		
		RAMPA Pendiente longitudinal, útil para desniveles = 3m K.4	RAMPA Pendiente transversal K.5	RAMPA Otras condiciones K.6
				Anchura según A+10% Areas de maniobra según B, C y D en llano Rellanos intermedios longitud en la dirección de circulación >150 Pasamanos disponer en rampa con pendiente >6% según L Pavimento antiderrapante
		ESCALERA Peldaños K.7	ESCALERA Otras condiciones K.8	
				

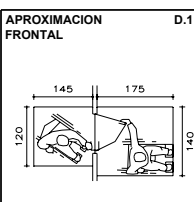
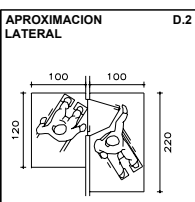

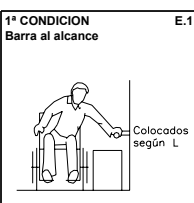

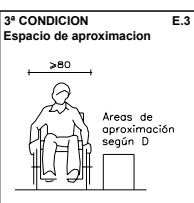

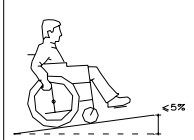
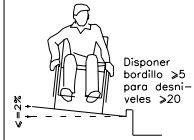

# DIFICULTAD DE MANIOBRA

PARAMETROS DE REFERENCIA

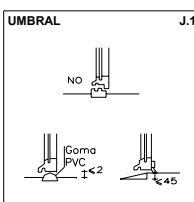
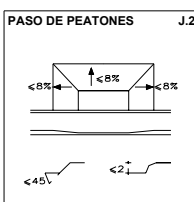
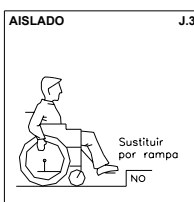
A		OBSTACULO AISLADO A.1	CIRCULACION A.2	DOBLE CIRCULACION A.3
				
		EN LINEA RECTA		
B		90 GRADOS B.1	180 GRADOS B.2	360 GRADOS B.3
				
		ROTACION		
C		LUGAR ABIERTO C.1	PASILLO ANCHO CONSTANTE C.2	PASILLO ANCHO VARIABLE C.3
				
		GIRO		
D		APROXIMACION FRONTAL D.1	APROXIMACION LATERAL D.2	
				
		PASAR PUERTA		
E		1ª CONDICION Barra al alcance E.1	2ª CONDICION Nivel asiento E.2	3ª CONDICION Espacio de aproximacion E.3
				
		TRANSFERENCIA		

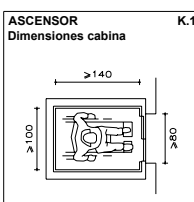

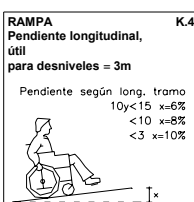
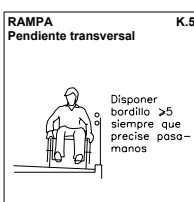

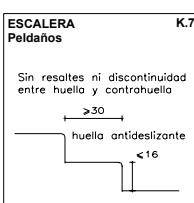
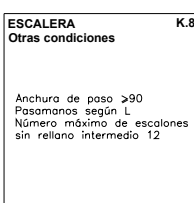

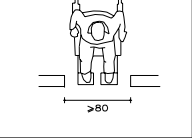
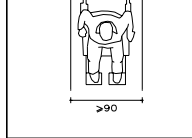
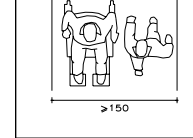

# DIFICULTAD DE SALVAR DESNIVELES

PARAMETROS DE REFERENCIA

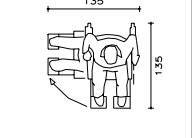
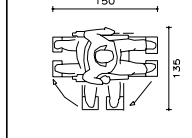
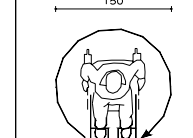
I		ITINERARIO En pendiente longitudinal I.1	ITINERARIO En pendiente transversal I.2	ITINERARIO EN PENDIENTE I.3 Dimensiones
				Anchura según A +10% Áreas de maniobra giro 90° según C +10% rotación según B +10% Área para franquear puerta según D en llano
		CONTINUO		
J		UMBRAL J.1	PASO DE PEATONES J.2	AISLADO J.3
				
		BRUSCO		Sustituir por rampa
K		ASCENSOR Dimensiones cabina K.1	ASCENSOR Disposición cabina y rellano K.2	ASCENSOR Otras condiciones K.3
				Rellano espera dimensiones según D Botonera colocación según F sobre plano vertical Pasamanos interior cabina disponer según L
		GRAN DESNIVEL		
		RAMPA Pendiente longitudinal, útil para desniveles = 3m K.4	RAMPA Pendiente transversal K.5	RAMPA Otras condiciones K.6
				Anchura según A+10% Áreas de maniobra según B, C y D en llano Rellanos intermedios longitud en la dirección de circulación >150 Pasamanos disponer en rampa con pendiente >6% según L Pavimento antiderrapante
		ESCALERA Peldaños K.7	ESCALERA Otras condiciones K.8	
				

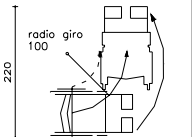
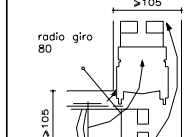
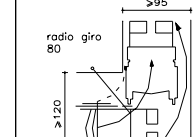

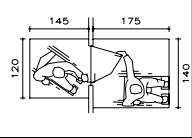
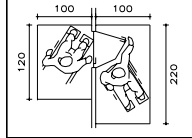

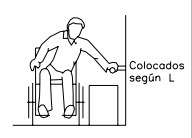
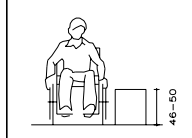
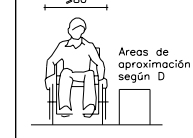



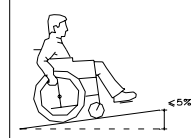
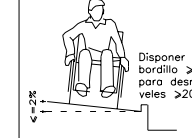

# DIFICULTAD DE MANIOBRA

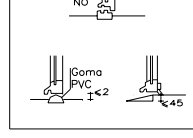
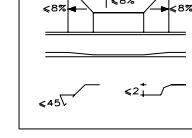
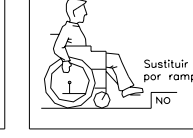
PARAMETROS DE REFERENCIA

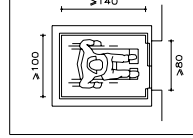
A		OBSTACULO AISLADO <b>A.1</b>	CIRCULACION <b>A.2</b>	DOBLE CIRCULACION <b>A.3</b>
				
		EN LINEA RECTA		
B		90 GRADOS <b>B.1</b>	180 GRADOS <b>B.2</b>	360 GRADOS <b>B.3</b>
				
		ROTACION		
C		LUGAR ABIERTO <b>C.1</b>	PASILLO ANCHO CONSTANTE <b>C.2</b>	PASILLO ANCHO VARIABLE <b>C.3</b>
				
		GIRO		
D		APROXIMACION FRONTAL <b>D.1</b>	APROXIMACION LATERAL <b>D.2</b>	
				
		PASAR PUERTA		
E		1ª CONDICION Barra al alcance <b>E.1</b>	2ª CONDICION Nivel asiento <b>E.2</b>	3ª CONDICION Espacio de aproximacion <b>E.3</b>
				
		TRANSFERENCIA		

# DIFICULTAD DE SALVAR DESNIVELES

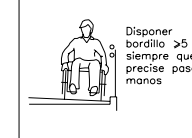
PARAMETROS DE REFERENCIA

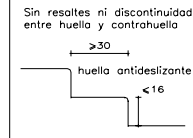
I		ITINERARIO En pendiente longitudinal <b>I.1</b>	ITINERARIO En pendiente transversal <b>I.2</b>	ITINERARIO EN PENDIENTE Dimensiones <b>I.3</b>
				Anchura según A +10% Áreas de maniobra giro 90° según C +10% rotación según B +10% Área para franquear puerta según D en llano
		CONTINUO		
J		UMBRAL <b>J.1</b>	PASO DE PEATONES <b>J.2</b>	AISLADO <b>J.3</b>
				
		BRUSCO		
K		ASCENSOR Dimensiones cabina <b>K.1</b>	ASCENSOR Disposición cabina y rellano <b>K.2</b>	ASCENSOR Otras condiciones <b>K.3</b>
				Rellano espera dimensiones según D Botonera colocación según F sobre plano vertical Pasamanos interior cabina disponer según L
		GRAN DESNIVEL		
		RAMPA Pendiente longitudinal, útil para desniveles = 3m <b>K.4</b>	RAMPA Pendiente transversal <b>K.5</b>	RAMPA Otras condiciones <b>K.6</b>
				Anchura según A+10% Áreas de maniobra según B, C y D en llano Rellanos intermedios longitud en la dirección de circulación >150 Pasamanos disponer en rampa con pendiente >6% según L Pavimento antiderrapante
		ESCALERA Peldaños <b>K.7</b>	ESCALERA Otras condiciones <b>K.8</b>	
			Anchura de paso >90 Pasamanos según L Número máximo de escalones sin rellano intermedio 12	

# DIFICULTAD DE MANIOBRA

PARAMETROS DE REFERENCIA

A

EN LINEA RECTA

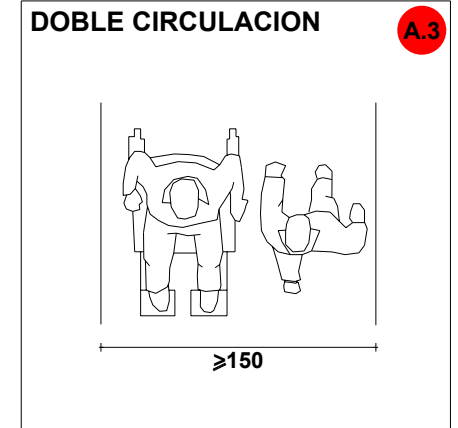
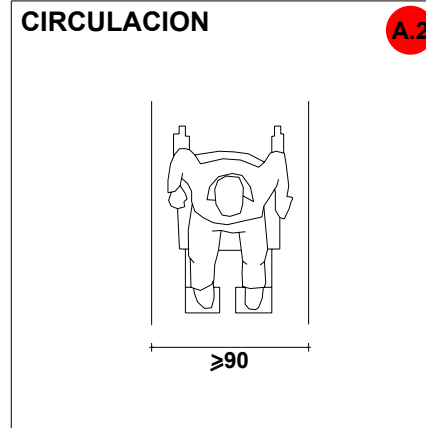
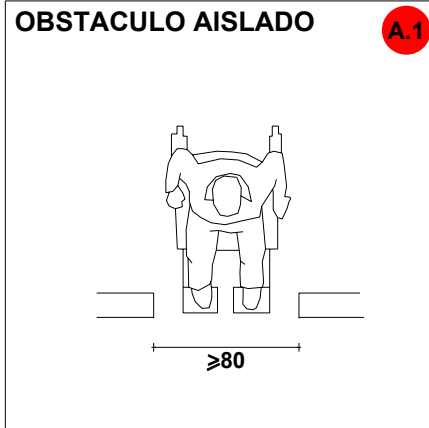

# DIFICULTAD DE MANIOBRA

PARAMETROS DE REFERENCIA

**B**



**ROTACION**

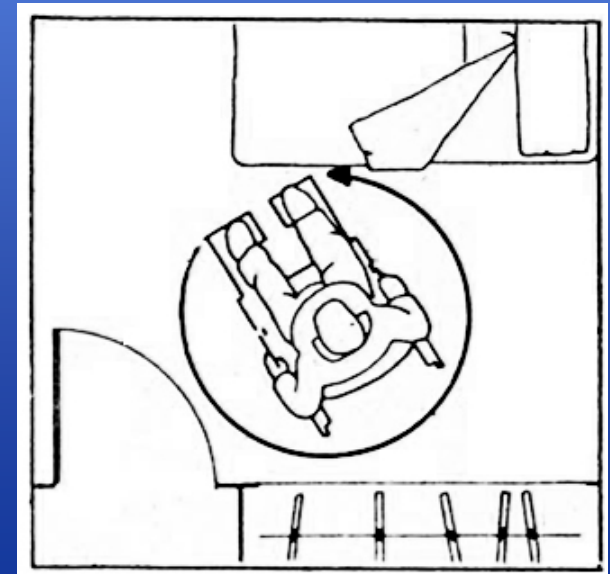
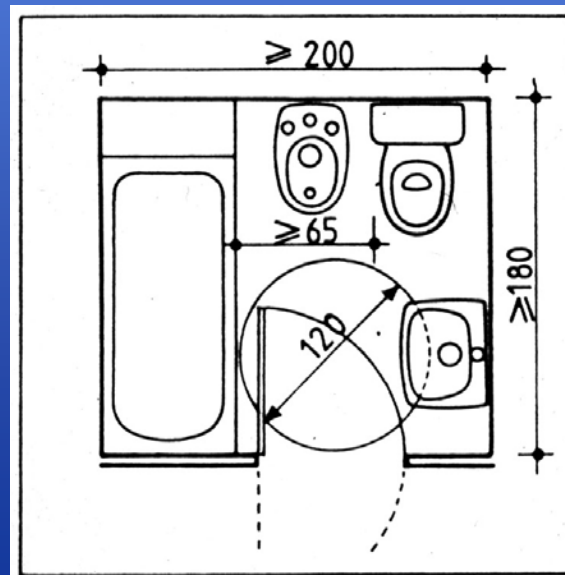
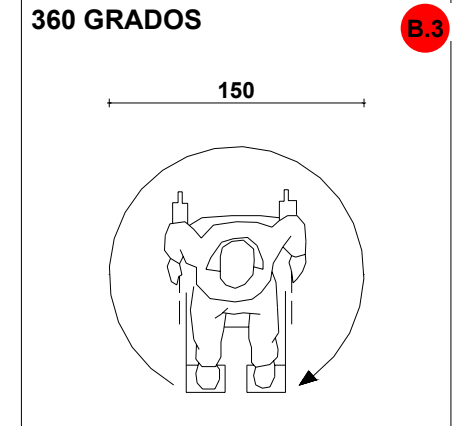
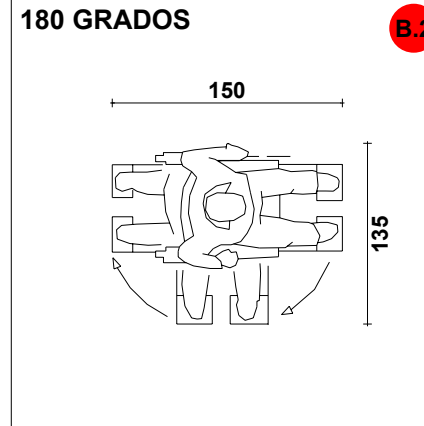
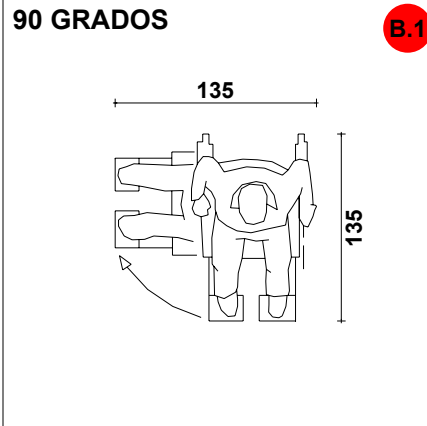



# DIFICULTAD DE MANIOBRA

PARAMETROS DE REFERENCIA

C



GIRO

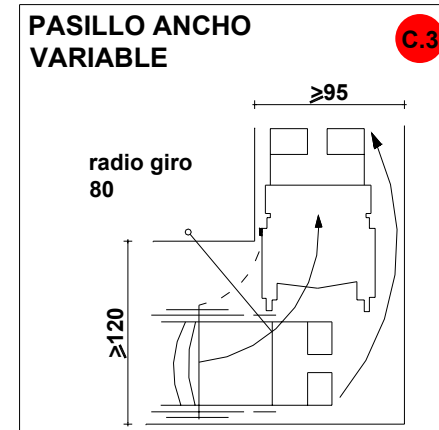
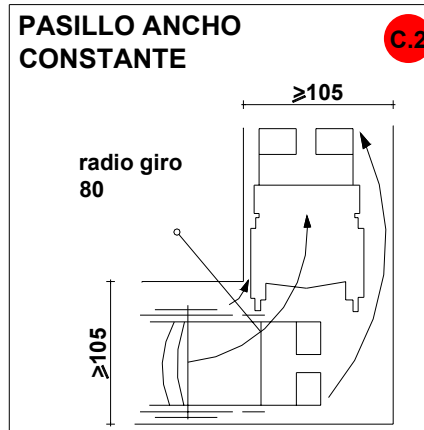
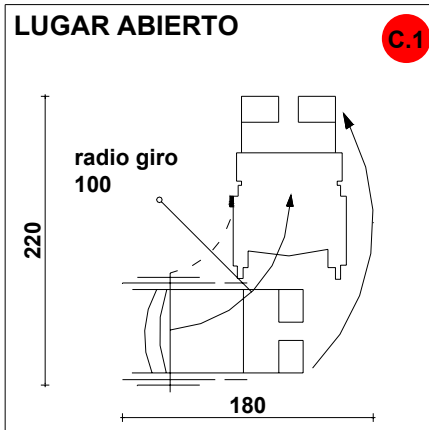

# DIFICULTAD DE MANIOBRA

PARAMETROS DE REFERENCIA

D

PASAR PUERTA

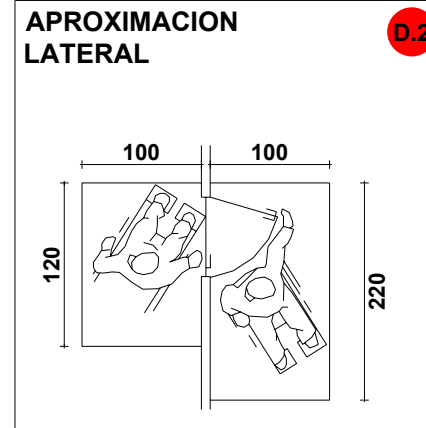
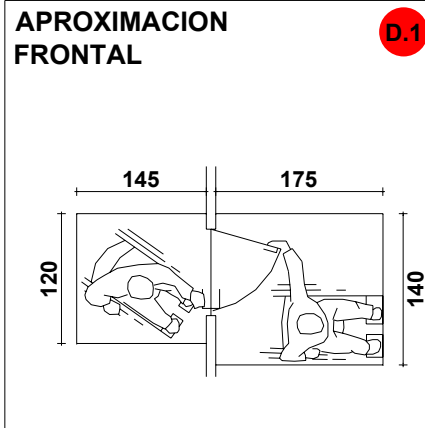

# DIFICULTAD DE MANIOBRA

PARAMETROS DE REFERENCIA

<b>Π</b>
<b>TRANSFERENCIA</b>

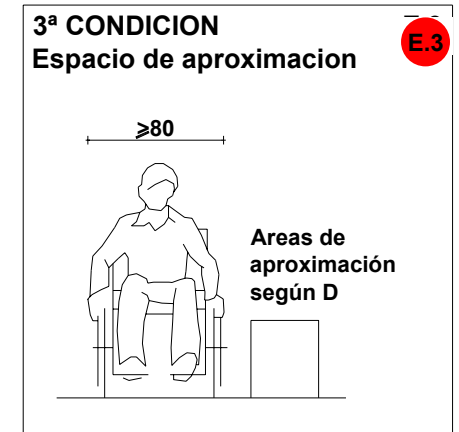
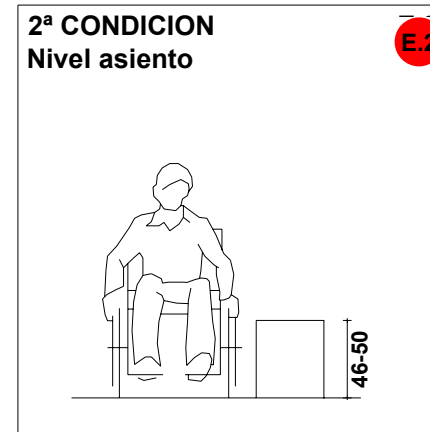
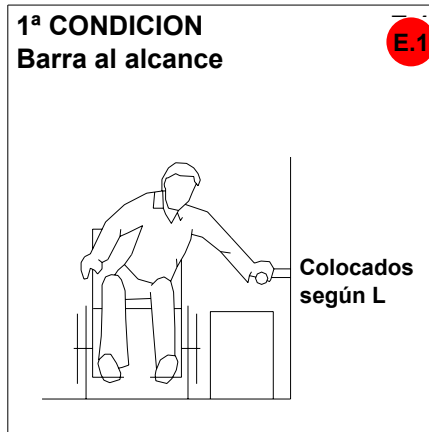

# DIFICULTAD DE SALVAR DESNIVELES

PARAMETROS DE REFERENCIA

I



ITINERARIO  
En pendiente longitudinal

1.1



CONTINUO

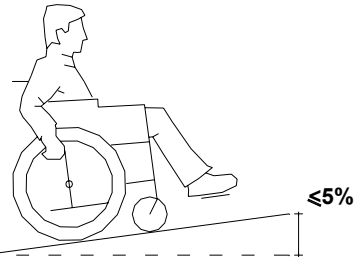

ITINERARIO  
En pendiente transversal

1.2



ITINERARIO EN PENDIENTE  
Dimensiones

1.3

Anchura según A +10%  
Áreas de maniobra  
giro 90° según C +10%  
rotación según B +10%  
Área para franquear puerta  
según D en llano



# DIFICULTAD DE SALVAR DESNIVELES

PARAMETROS DE REFERENCIA

J  
BRUSCO

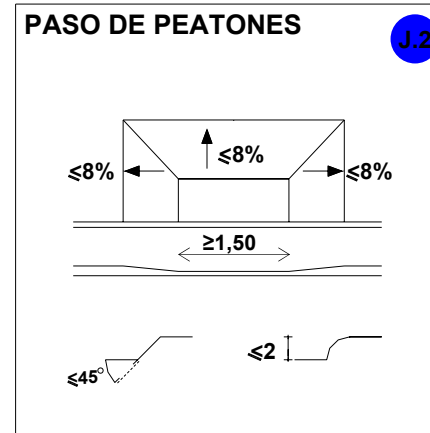
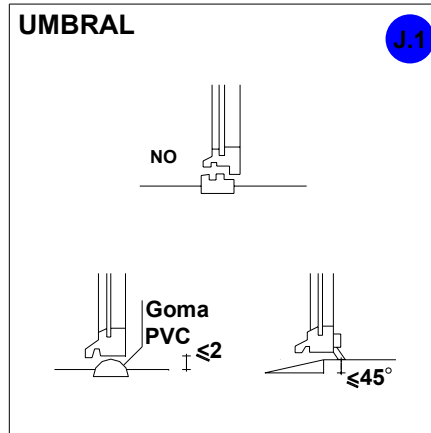



# DIFICULTAD DE SALVAR DESNIVELES

PARAMETROS DE REFERENCIA

K

GRAN DESNIVEL



ASCENSOR  
Dimensiones cabina

K.1

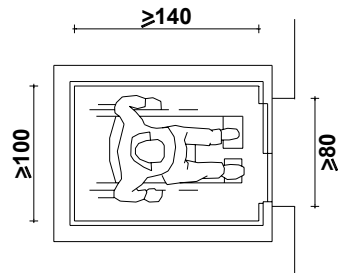

ASCENSOR  
Disposición cabina y rellano

K.2

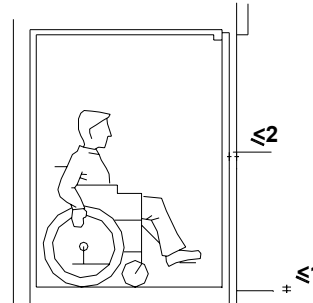

ASCENSOR  
Otras condiciones

K.3

Rellano espera  
dimensiones según D  
Botonera  
colocación según F  
sobre plano vertical  
Pasamanos interior cabina  
disponer según L



# DIFICULTAD DE SALVAR DESNIVELES

PARAMETROS DE REFERENCIA

K

GRAN DESNIVEL



**RAMPA**  
Pendiente longitudinal,  
útil  
para desniveles = 3m K.4

Pendiente según long. tramo  
 $>10$  y  $<15$ ,  $x \leq 6\%$   
 $<10$ ,  $x \leq 8\%$   
 $<3$ ,  $x \leq 10\%$

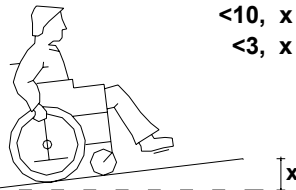

**RAMPA**  
Pendiente transversal K.5

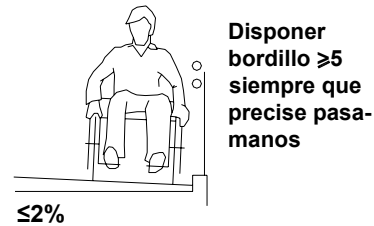

Disponer  
bordillo  $\geq 5$   
siempre que  
precise pasa-  
manos

$\leq 2\%$

**RAMPA**  
Otras condiciones K.6

Anchura según A+10%  
Áreas de maniobra según B,  
C y D en llano  
Rellanos intermedios longitud  
en la dirección de circulación  
 $\geq 150$   
Pasamanos disponer en rampa  
con pendiente  $\geq 6\%$  según L  
Pavimento antideslizante



2004 6 3

# DIFICULTAD DE SALVAR DESNIVELES

PARAMETROS DE REFERENCIA

**K**

**GRAN DESNIVEL**



**ESCALERA**  
Peldaños

**K.7**

Sin resaltes ni discontinuidad  
entre huella y contrahuella

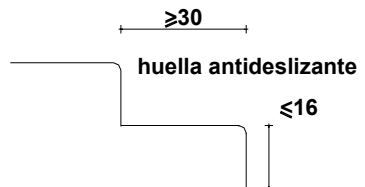

**ESCALERA**  
Otras condiciones

**K.8**

Anchura de paso  $\geq 90$   
Pasamanos según L  
Número máximo de escalones  
sin rellano intermedio 12





# DIFICULTAD DE ALCANCE

PARAMETROS DE REFERENCIA

F		<b>S. PLANO HORIZONTAL F.1</b> Altura cómoda plano de trabajo	<b>S. PLANO HORIZONTAL F.2</b> Alcance sobre plano de trabajo	<b>S. PLANO HORIZONTAL F.3</b> Espacio bajo plano de trabajo
MANUAL		<b>S. PLANO VERTICAL F.4</b> Alturas	<b>S. PLANO VERTICAL F.5</b> Distancia no útil	
G		<b>AL EXTERIOR G.1</b>	<b>S. PLANO HORIZONTAL G.2</b>	<b>SOBRE UN ESPEJO G.3</b>
VISUAL		<b>PARA DETECTAR O EVITAR OBSTACULOS G.4</b>	<b>PARA DETECTAR O EVITAR AGUJEROS G.5</b>	<b>PARA DETERMINAR DIRECCIONES G.6</b>
				<p>Disponer un elemento guía continuo. Bien sea:</p> <ol style="list-style-type: none"> <li>Propio del itinerario, bordillo, pared, mobiliario</li> <li>Añadido al itinerario, pasamanos, franja de textura diferenciada, sonido</li> </ol>
H		<b>PARA COMUNICARSE CON EL ENTORNO H.1</b>	<b>PARA OBTENER INFORMACION GRAFICA G.7</b>	
		<ol style="list-style-type: none"> <li>Complementar sistemas de aviso y alarma sonora con impactos visuales.</li> <li>Disponer una clara y completa señalización e información escrita.</li> </ol>	<ol style="list-style-type: none"> <li>Complementar mensajes visuales con sistema táctil (relieve, braille) o acústico (habla, código sonoro).</li> <li>Adecuar tamaño, grafismo y color de la señalización a las personas con capacidad visual reducidas.</li> <li>Normalizar sistemas de información</li> </ol>	

# DIFICULTAD DE CONTROL

PARAMETROS DE REFERENCIA

L		<b>PASAMANOS Características L.1</b>	<b>PASAMANOS Colocación en rampa o llano L.2</b>	<b>PASAMANOS Colocación en escaleras L.3</b>
DEL EQUILIBRIO		<b>BARRAS Características L.4</b>	<b>BARRAS Colocación w.c. y transferencia L.5</b>	<b>BARRAS Colocación en bañera L.6</b>
M		<b>PAVIMENTO Antideslizante L.7</b>	<b>PAVIMENTO Compacto y regular L.8</b>	<b>PAVIMENTO Fijado al elemento soporte L.9</b>
MANIPULACION		<b>INTERRUPTORES Y MANUBRIOS Colocación M.1</b>	<b>INTERRUPTORES Características M.2</b>	<b>MANUBRIOS Características M.3</b>
		<p>Según F (alcance manual) sobre un plano vertical</p>		
M		<b>GRIFOS Colocación M.4</b>	<b>GRIFOS Características M.5</b>	
		<p>Según F (alcance manual) sobre un plano horizontal</p>		

# DIFICULTAD DE ALCANCE

PARAMETROS DE REFERENCIA

F		<b>S. PLANO HORIZONTAL F.1</b> Altura cómoda plano de trabajo 	<b>S. PLANO HORIZONTAL F.2</b> Alcance sobre plano de trabajo 	<b>S. PLANO HORIZONTAL F.3</b> Espacio bajo plano de trabajo 
		<b>S. PLANO VERTICAL F.4</b> Alturas 	<b>S. PLANO VERTICAL F.5</b> Distancia no útil 	
G		<b>AL EXTERIOR G.1</b> 	<b>S. PLANO HORIZONTAL G.2</b> 	<b>SOBRE UN ESPEJO G.3</b> 
		<b>PARA DETECTAR O EVITAR OBSTACULOS G.4</b> 	<b>PARA DETECTAR O EVITAR AGUJEROS G.5</b> 	<b>PARA DETERMINAR DIRECCIONES G.6</b> Disponer un elemento guía continuo. Bien sea: a) Propio del itinerario, bordillo, pared, mobiliario b) Añadido al itinerario, pasamanos, franja de textura diferenciada, sonido
H		<b>PARA COMUNICARSE CON EL ENTORNO H.1</b> a) Complementar sistemas de aviso y alarma sonora con impactos visuales. b) Disponer una clara y completa señalización e información escrita.	<b>PARA OBTENER INFORMACION GRAFICA G.7</b> a) Complementar mensajes visuales con sistema táctil (relieve, braille) o acústico (habla, código sonoro). b) Adecuar tamaño, grafismo y color de la señalización a las personas con capacidad visual reducidas. c) Normalizar sistemas de información	







# DIFICULTAD DE CONTROL

PARAMETROS DE REFERENCIA

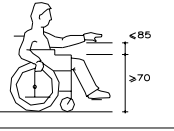
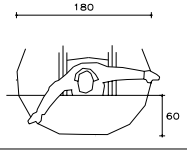
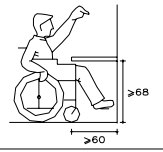
L	 	<b>PASAMANOS Características L.1</b> Fijación firme por la parte inferior Sección igual o equivalente a $\phi 4 \times 5$ Separación $\geq 4$ 	<b>PASAMANOS Colocación en rampa o llano L.2</b> 	<b>PASAMANOS Colocación en escaleras L.3</b> 
		<b>BARRAS Características L.4</b> Fijación firme Sección $\phi 4 \times 5$ Separación obstáculos $\geq 4$ 	<b>BARRAS Colocación w.c. y transferencia L.5</b> 	<b>BARRAS Colocación en bañera L.6</b> 
M	 	<b>PAVIMENTO Antideslizante L.7</b> Locales húmedos Al exterior En desniveles 	<b>PAVIMENTO Compacto y regular L.8</b> 	<b>PAVIMENTO Fijado al elemento soporte L.9</b> 
		<b>INTERRUPTORES Y MANUBRIOS Colocación M.1</b> Según F (alcance manual) sobre un plano vertical	<b>INTERRUPTORES Características M.2</b> 	<b>MANUBRIOS Características M.3</b> 
M	 	<b>GRIFOS Colocación M.4</b> Según F (alcance manual) sobre un plano horizontal	<b>GRIFOS Características M.5</b> 	

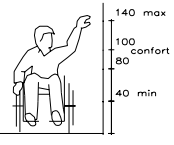
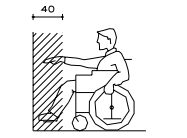
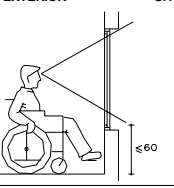
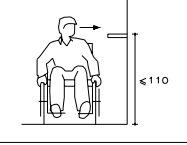
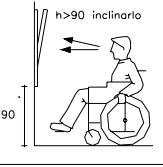

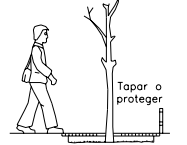









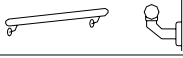
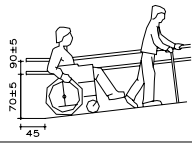
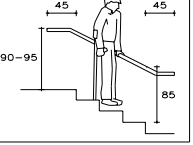

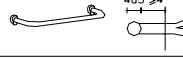
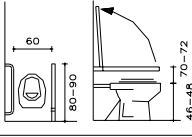
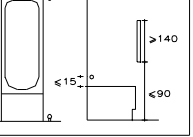
# DIFICULTAD DE ALCANCE

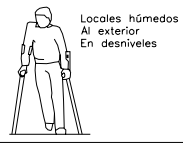
PARAMETROS DE REFERENCIA

F MANUAL		<b>S. PLANO HORIZONTAL F.1</b> Altura cómoda plano de trabajo 	<b>S. PLANO HORIZONTAL F.2</b> Alcance sobre plano de trabajo 	<b>S. PLANO HORIZONTAL F.3</b> Espacio bajo plano de trabajo 	
			<b>S. PLANO VERTICAL F.4</b> Alturas 	<b>S. PLANO VERTICAL F.5</b> Distancia no útil 	
		<b>AL EXTERIOR G.1</b> 	<b>S. PLANO HORIZONTAL G.2</b> 	<b>SOBRE UN ESPEJO G.3</b> 	
		<b>PARA DETECTAR O EVITAR OBSTACULOS G.4</b> 	<b>PARA DETECTAR O EVITAR AGUJEROS G.5</b> 	<b>PARA DETERMINAR DIRECCIONES G.6</b> Disponer un elemento guía continuo. Bien sea: a) Propio del itinerario, bordillo, pared, mobiliario b) Añadido al itinerario, pasamanos, franja de textura diferenciada, sonido	
H AUDITIVO		<b>PARA COMUNICARSE CON EL ENTORNO H.1</b> a) Complementar sistemas de aviso y alarma sonora con impactos visuales. b) Disponer una clara y completa señalización e información escrita.	<b>PARA OBTENER INFORMACION GRAFICA G.7</b> a) Complementar mensajes visuales con sistema táctil (relieve, braille) o acústico (habla, código sonoro). b) Adecuar tamaño, grafismo y color de la señalización a las personas con capacidad visual reducidas. c) Normalizar sistemas de información		

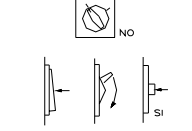
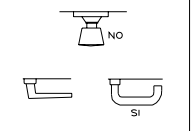
# DIFICULTAD DE CONTROL

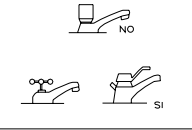
PARAMETROS DE REFERENCIA

L DEL EQUILIBRIO	 	<b>PASAMANOS Características L.1</b> Fijación firme por la parte inferior Sección igual o equivalente a $\phi 4 \times 5$ Separación $\geq 4$ 	<b>PASAMANOS Colocación en rampa o llano L.2</b> 	<b>PASAMANOS Colocación en escaleras L.3</b> 	
		 	<b>BARRAS Características L.4</b> Fijación firme Sección $\phi 4 \times 5$ Separación obstáculos $\geq 4$ 	<b>BARRAS Colocación w.c. y transferencia L.5</b> 	<b>BARRAS Colocación en bañera L.6</b> 
		 	<b>PAVIMENTO Antideslizante L.7</b> Locales húmedos Al exterior En desniveles 	<b>PAVIMENTO Compacto y regular L.8</b> 	<b>PAVIMENTO Fijado al elemento soporte L.9</b> 
M MANIPULACION	 	<b>INTERRUPTORES Y MANUBRIOS Colocación M.1</b> Según F (alcance manual) sobre un plano vertical	<b>INTERRUPTORES Características M.2</b> 	<b>MANUBRIOS Características M.3</b> 	
		 	<b>GRIFOS Colocación M.4</b> Según F (alcance manual) sobre un plano horizontal	<b>GRIFOS Características M.5</b> 	

# DIFICULTAD DE ALCANCE

PARAMETROS DE REFERENCIA

F		<b>S. PLANO HORIZONTAL</b> Altura cómoda plano de trabajo 	<b>S. PLANO HORIZONTAL</b> Alcance sobre plano de trabajo 	<b>S. PLANO HORIZONTAL</b> Espacio bajo plano de trabajo 	
		<b>S. PLANO VERTICAL</b> Alturas 	<b>S. PLANO VERTICAL</b> Distancia no útil 		
G		<b>AL EXTERIOR</b> 	<b>S. PLANO HORIZONTAL</b> 	<b>SOBRE UN ESPEJO</b> 	
		<b>PARA DETECTAR O EVITAR OBSTACULOS</b> 	<b>PARA DETECTAR O EVITAR AGUJEROS</b> 	<b>PARA DETERMINAR DIRECCIONES</b> Disponer un elemento guía continuo. Bien sea: a) Propio del itinerario, bordillo, pared, mobiliario b) Añadido al itinerario, pasamanos, franja de textura diferenciada, sonido	
H		<b>PARA COMUNICARSE CON EL ENTORNO</b> a) Complementar sistemas de aviso y alarma sonora con impactos visuales. b) Disponer una clara y completa señalización e información escrita.	<b>PARA OBTENER INFORMACION GRAFICA</b> a) Complementar mensajes visuales con sistema táctil (relieve, braille) o acústico (habla, código sonoro). b) Adecuar tamaño, grafismo y color de la señalización a las personas con capacidad visual reducidas. c) Normalizar sistemas de información		

# DIFICULTAD DE CONTROL

PARAMETROS DE REFERENCIA

L		<b>PASAMANOS</b> Características Fijación firme por la parte inferior Sección igual o equivalente a $\phi 4 \times 5$ Separación $\geq 4$ 	<b>PASAMANOS</b> Colocación en rampa o llano 	<b>PASAMANOS</b> Colocación en escaleras 
		<b>BARRAS</b> Características Fijación firme Sección $\phi 4 \times 5$ Separación obstáculos $\geq 4$ 	<b>BARRAS</b> Colocación w.c. y transferencia 	<b>BARRAS</b> Colocación en bañera 
M		<b>PAVIMENTO Antideslizante</b> Locales húmedos Al exterior En desniveles 	<b>PAVIMENTO Compacto y regular</b> 	<b>PAVIMENTO Fijado al elemento soporte</b> 
		<b>INTERRUPTORES Y MANUBRIOS</b> Colocación Según F (alcance manual) sobre un plano vertical	<b>INTERRUPTORES</b> Características 	<b>MANUBRIOS</b> Características 
M		<b>GRIFOS</b> Colocación Según F (alcance manual) sobre un plano horizontal	<b>GRIFOS</b> Características 	

# DIFICULTAD DE ALCANCE

PARAMETROS DE REFERENCIA

<b>F</b>
<b>MANUAL</b>

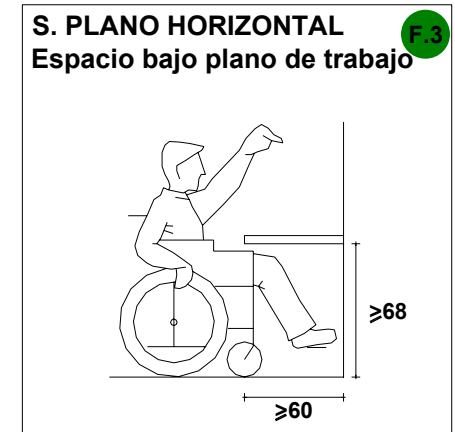
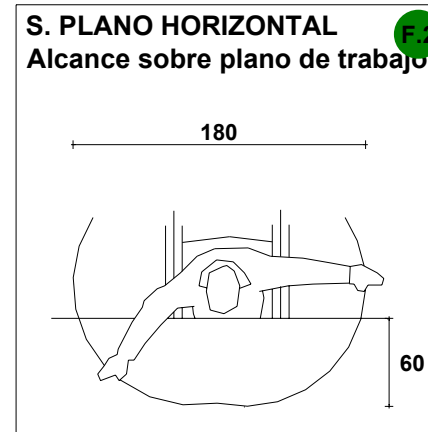
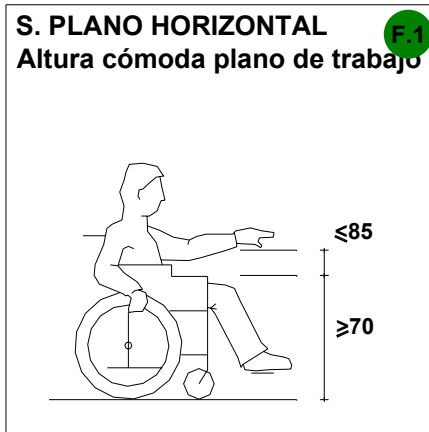

# DIFICULTAD DE ALCANCE

PARAMETROS DE REFERENCIA

F



MANUAL

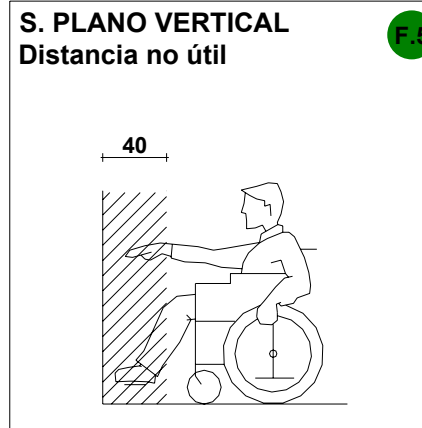
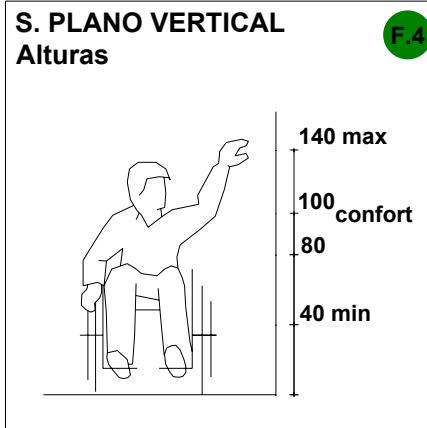



# DIFICULTAD DE ALCANCE

PARAMETROS DE REFERENCIA

G



VISUAL

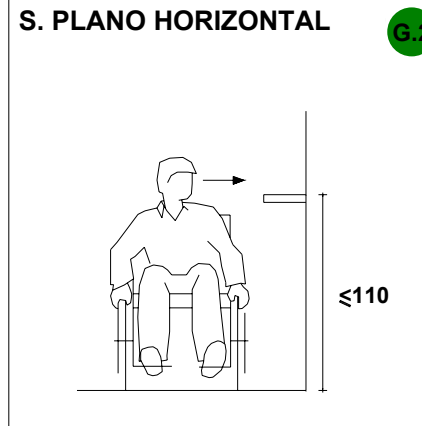
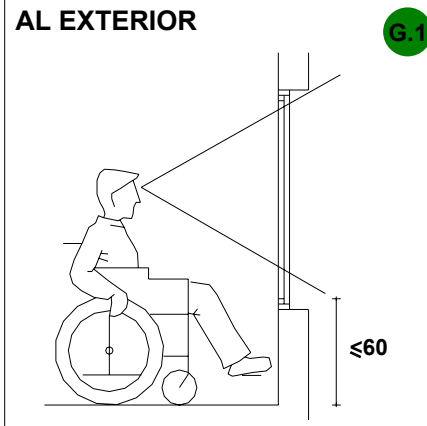

# DIFICULTAD DE ALCANCE

PARAMETROS DE REFERENCIA

G



VISUAL

PARA DETECTAR O EVITAR OBSTACULOS

G.4



PARA DETECTAR O EVITAR AGUJEROS

G.5

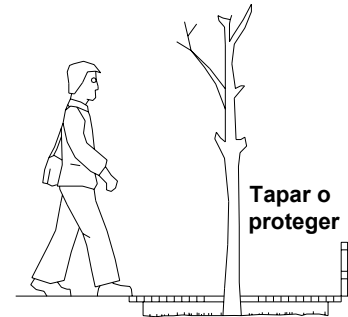

PARA DETERMINAR DIRECCIONES

G.6

Disponer un elemento guía continuo.  
Bien sea:

- Propio del itinerario, bordillo, pared, mobiliario
- Añadido al itinerario, pasamanos, franja de textura diferenciada, sonido





# DIFICULTAD DE ALCANCE

PARAMETROS DE REFERENCIA

H



PARA COMUNICARSE  
CON EL ENTORNO

H.1

- a) Complementar sistemas de aviso y alarma sonora con impactos visuales.
- b) Disponer una clara y completa señalización e información escrita.

AUDITIVO

PARA OBTENER  
INFORMACION GRAFICA

G.7

- a) Complementar mensajes visuales con sistematáctil (relieve, braille) o acústico (habla, código sonoro).
- b) Adecuar tamaño, grafismo y color de la señalización a las personas con capacidad visual reducidas.
- c) Normalizar sistemas de información

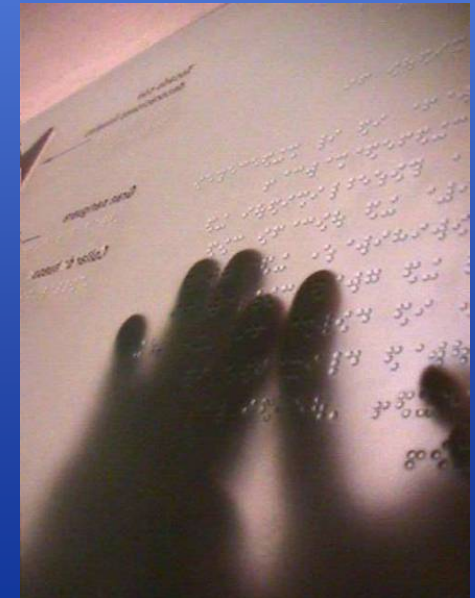

# DIFICULTAD DE CONTROL

PARAMETROS DE REFERENCIA

DEL EQUILIBRIO



**PASAMANOS**  
Características L.1

Fijación firme por la parte inferior  
Sección igual o equivalente a  $\text{Ø}4\text{a}5$   
Separación  $\geq 4$

$4\text{a}5 \geq 4$

**PASAMANOS**  
Colocación en rampa o llano L.2

**PASAMANOS**  
Colocación en escaleras L.3



# DIFICULTAD DE CONTROL

PARAMETROS DE REFERENCIA

DEL EQUILIBRIO



**BARRAS**  
Características L.4

Fijación firme  
Sección  $\varnothing 4a5$   
Separación obstáculos  $\geq 4$

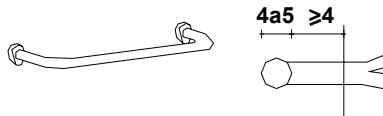

**BARRAS**  
Colocación w.c. y transferencia L.5

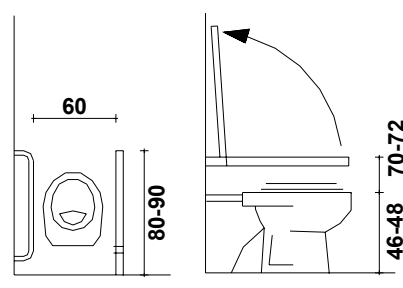

**BARRAS**  
Colocación en bañera L.6

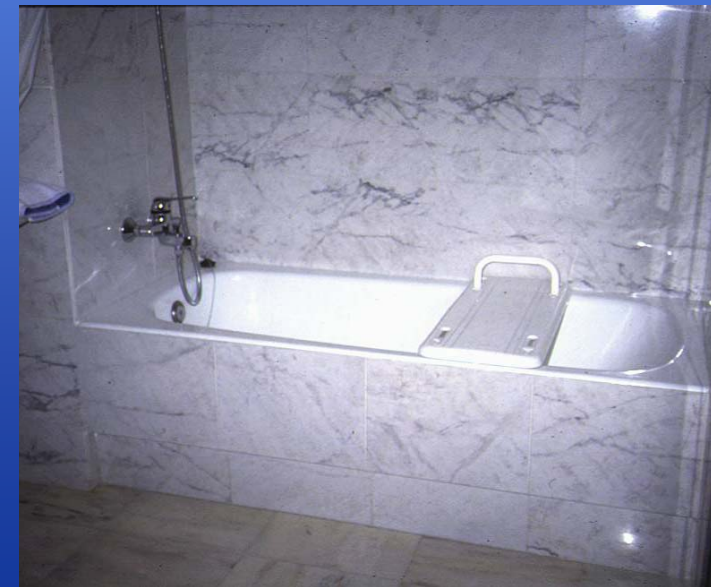
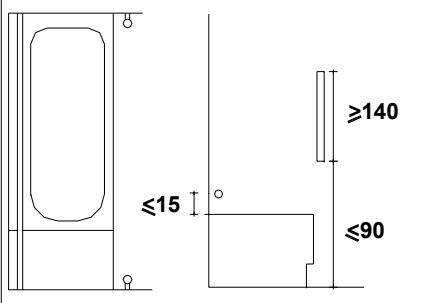

# DIFICULTAD DE CONTROL

PARAMETROS DE REFERENCIA

DEL EQUILIBRIO



**PAVIMENTO Antideslizante** L.7



Locales húmedos  
Al exterior  
En desniveles

**PAVIMENTO Compacto y regular** L.8



NO

**PAVIMENTO Fijado al elemento soporte** L.9



NO





# DIFICULTAD DE CONTROL

PARAMETROS DE REFERENCIA

M

MANIPULACION



**INTERRUPTORES Y  
MANUBRIOS**  
Colocación

M.1

Según F (alcance manual)  
sobre un plano vertical

**INTERRUPTORES**  
Características

M.2



NO

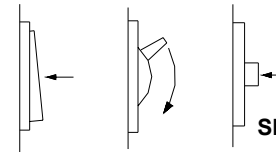

SI

**MANUBRIOS**  
Características

M.3



NO

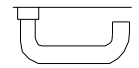
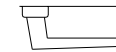

SI



# DIFICULTAD DE CONTROL

PARAMETROS DE REFERENCIA

M

MANIPULACION



GRIFOS  
Colocación

M.4

Según F (alcance manual)  
sobre un plano horizontal

GRIFOS  
Características

M.5

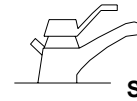
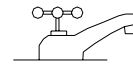
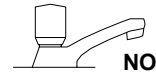

# 1.-A general reflection on ...

People's relations with their physical environments:

- What kinds of problems arise?
- What alternatives does architecture offer

# 2.-Boundaries based on ...

User types:

- walkers, wheel-chair users, sensory handicaps

Types of difficulties:

- manoeuvring, changing levels, reaching, controlling

Accessibility level:

- adapted, practicable, convertible

# 3.-Precision in ...

Reference parameters

# 4.-Examples of application ...

Old-age people's homes : "Trinitat" and "Llar Ancianitat"

# 5.-Appendix: Technologies for accessibility

"Active" technologies in improving personal autonomy at home



# Residència La Trinitat

Barcelona

Construction: 1985

Places: 48 residential · 40 day centre

Owned by: Generalitat of Catalonia



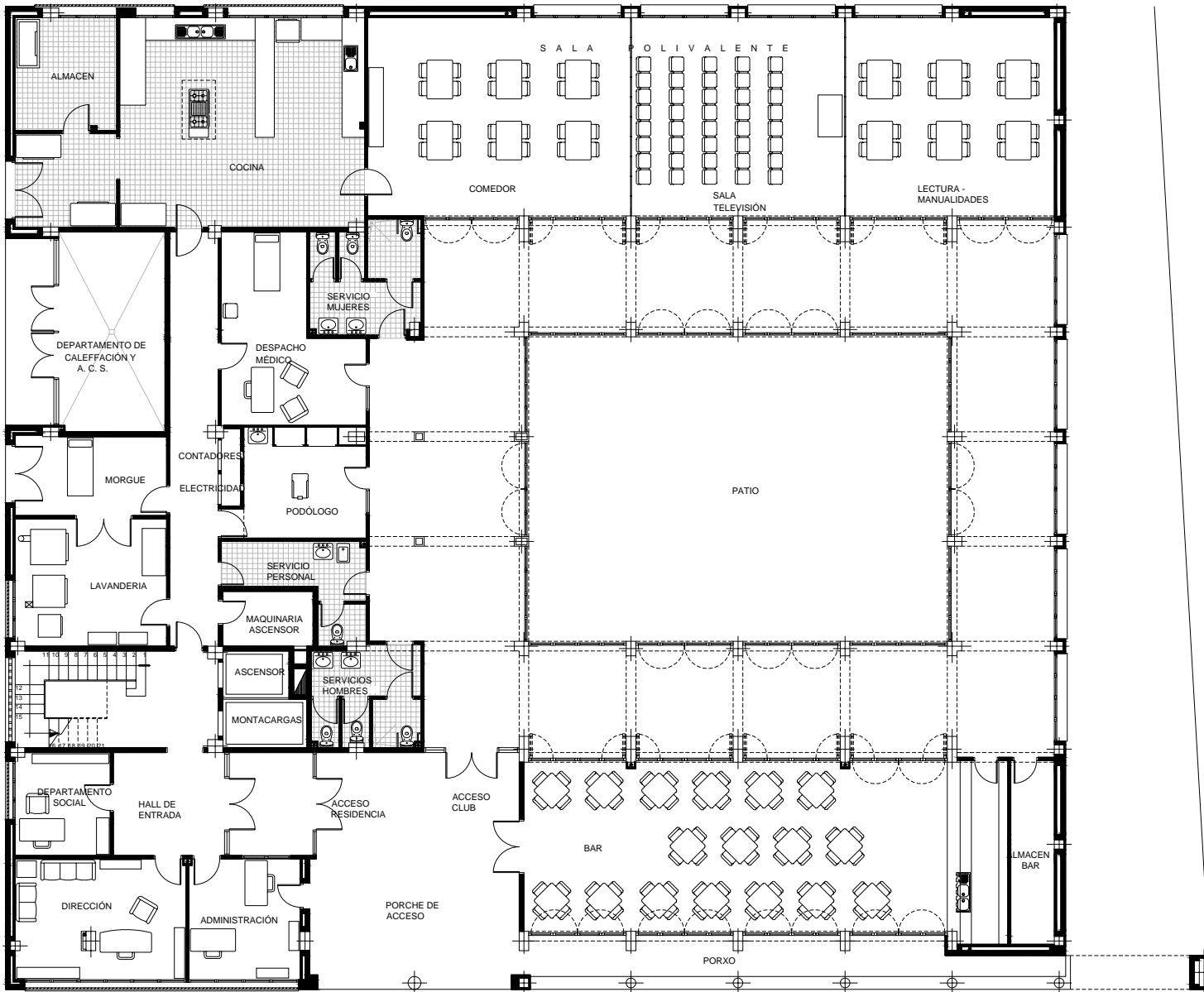

# GROUND FLOOR

GF
1st F
GF
1st F
GF
GF
GF
GF
GF
GF

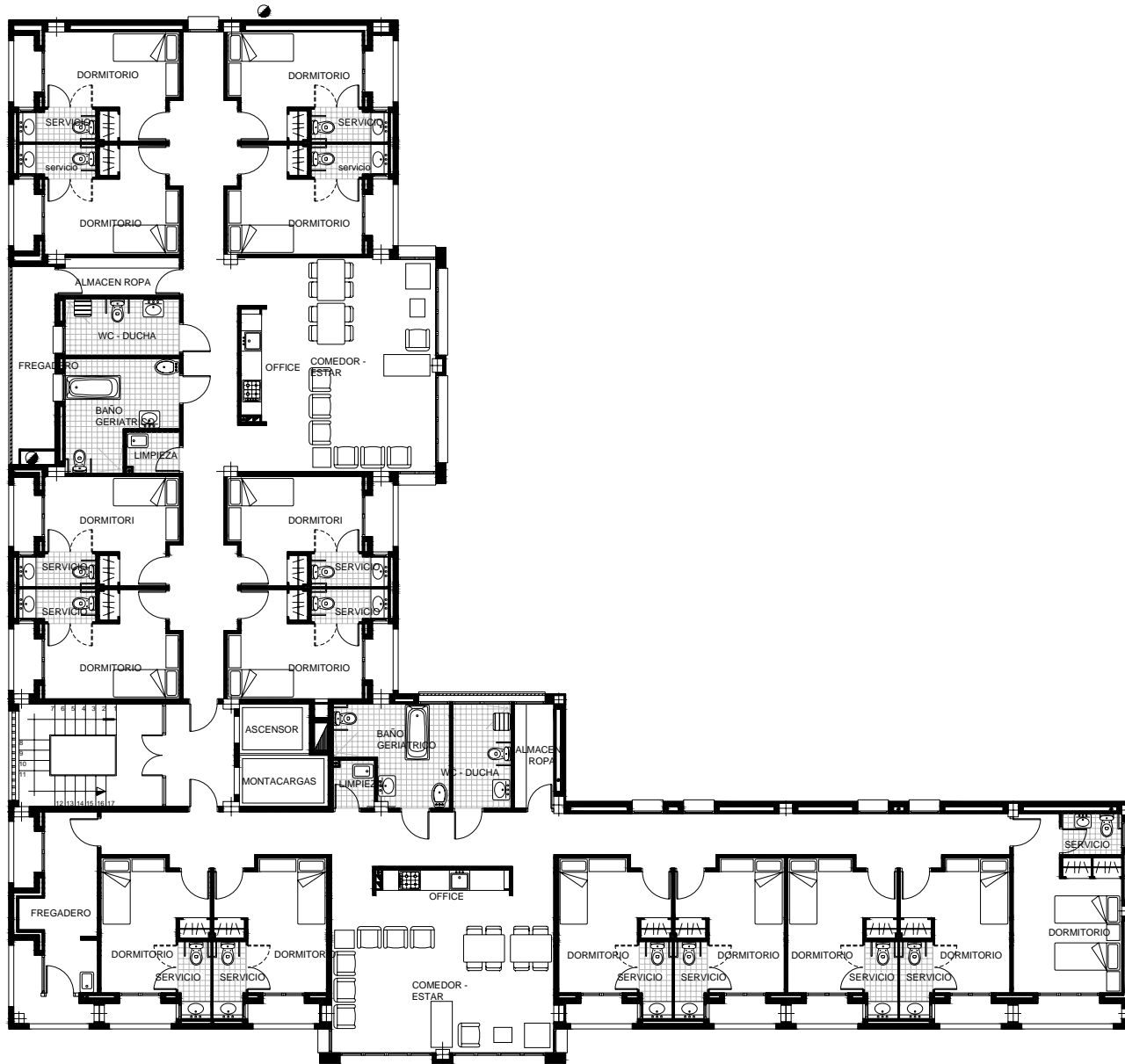

**TYPICAL FLOOR**

G F
1st F
G F
1st F
1st F
1st F
1st F
1st F
1st F
1st F

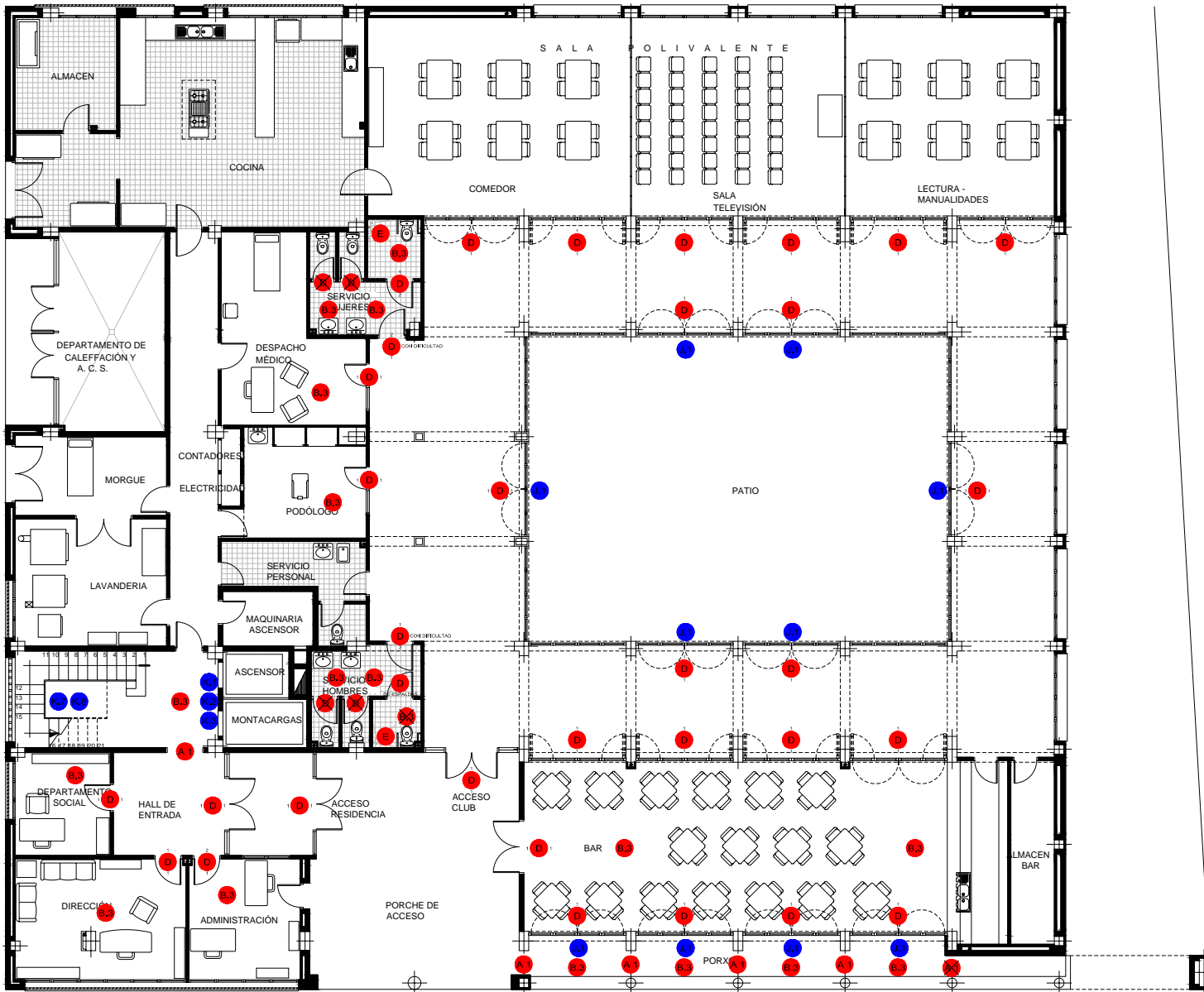

- GF
- 1st F
- GF
- 1st F
- GF
- GF
- GF
- GF
- GF
- GF
- GF

**GROUND FLOOR  
(movement)**

**Hard to manoeuvre  
Hard to negotiate**



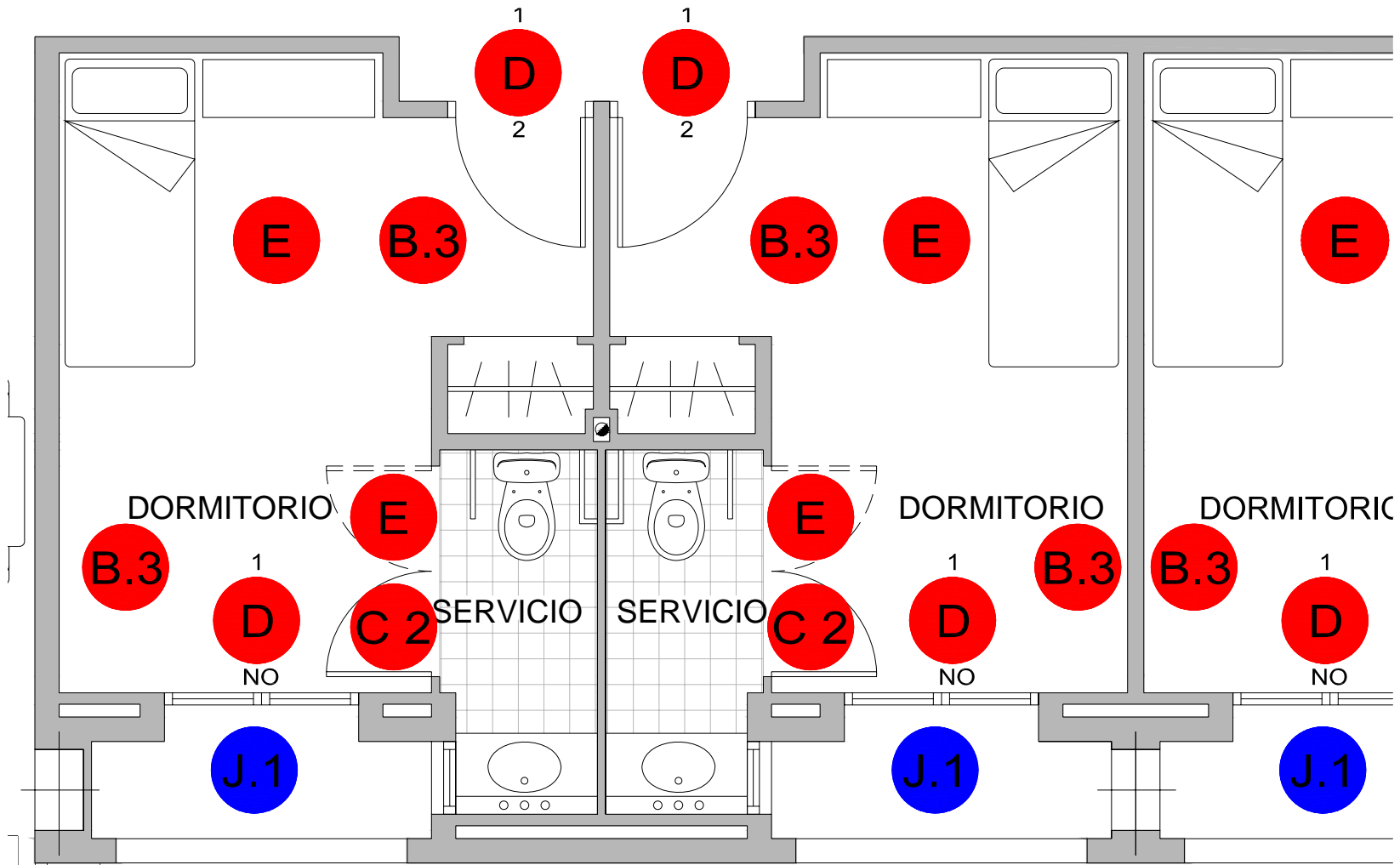

**BEDROOM.** Hard to manoeuvre  
Hard to negotiate

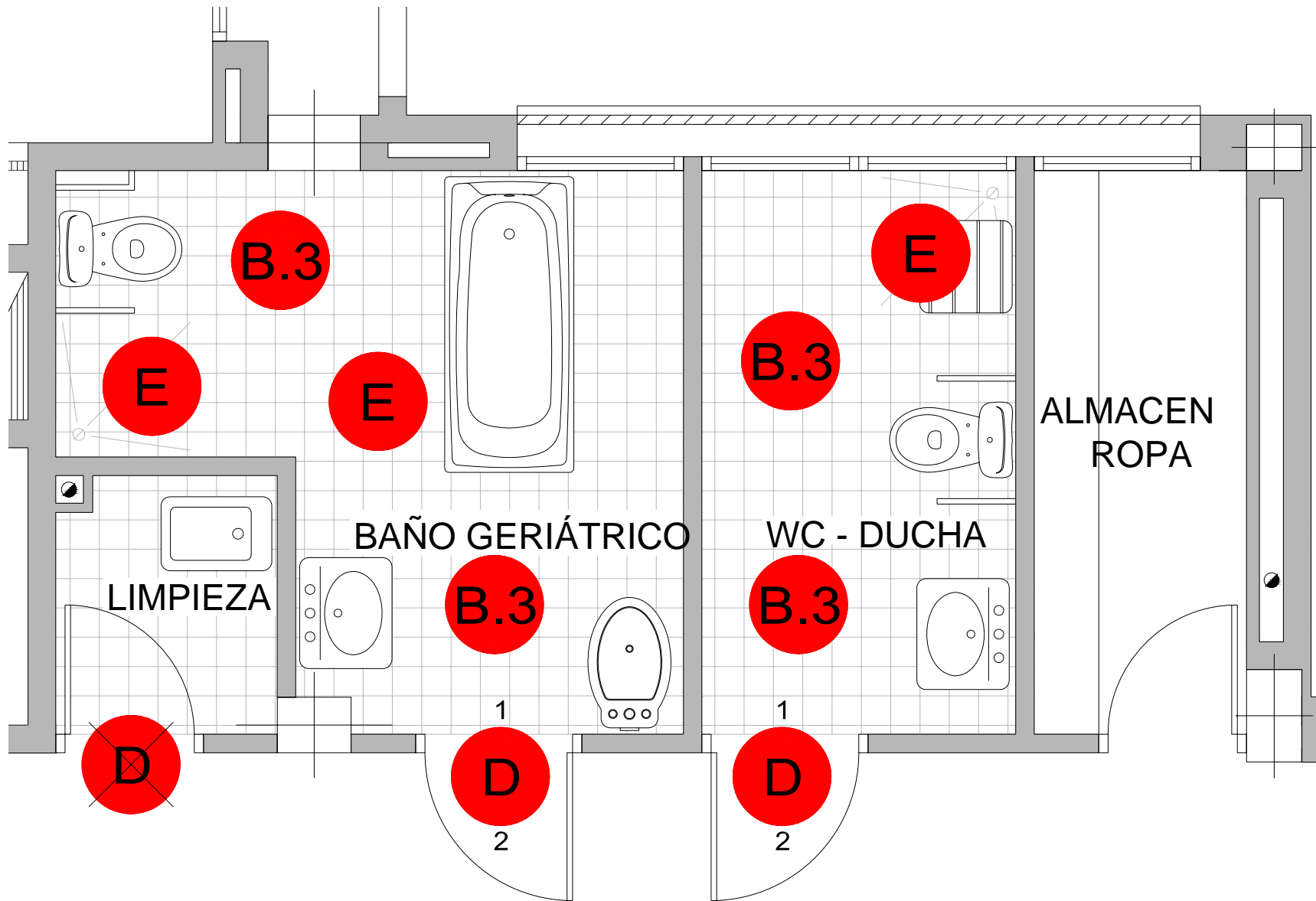

**SANITARY FACILITIES.**

**Hard to manoeuvre**  
**Hard to negotiate**

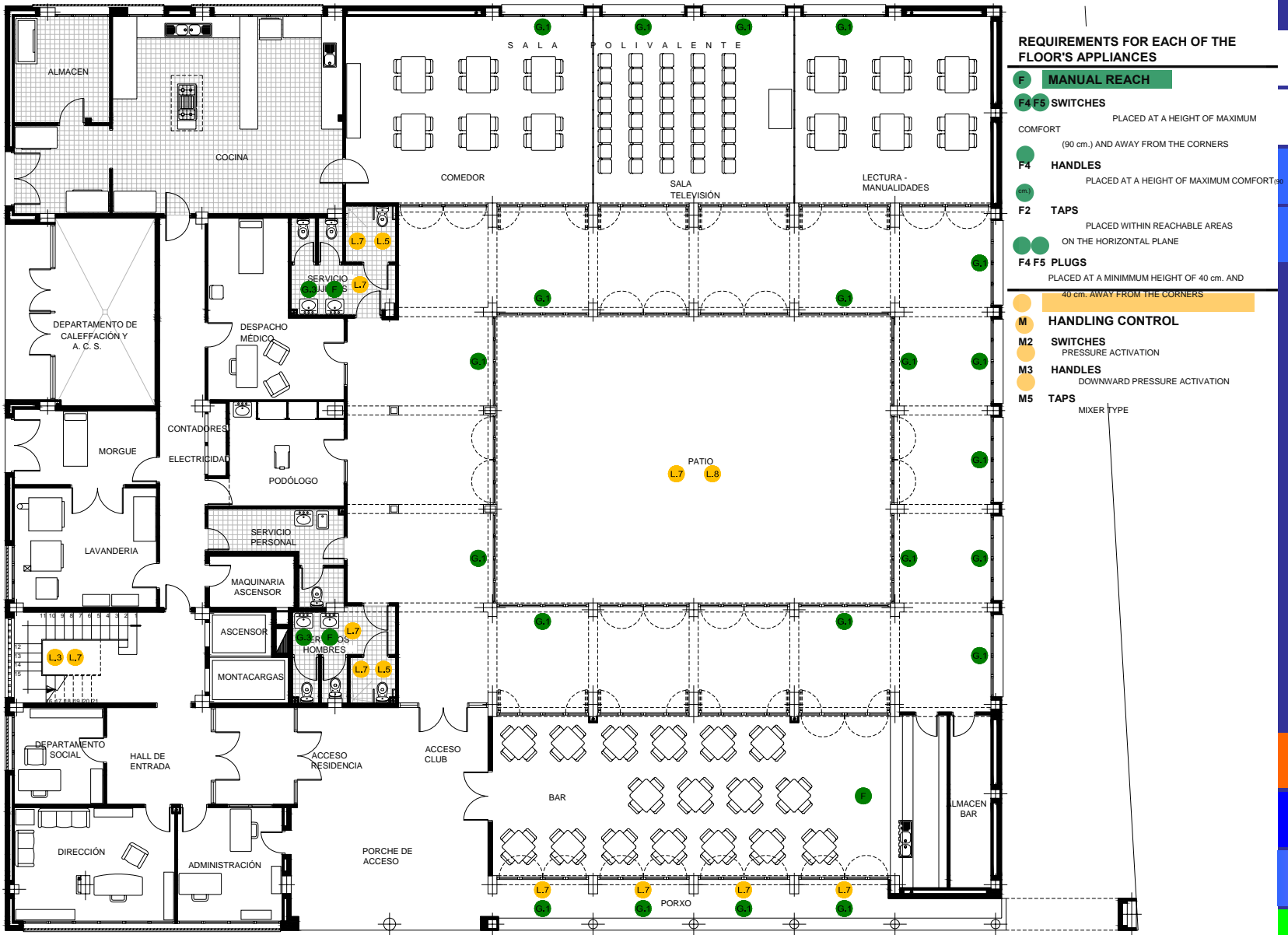

G F

1st F

G F

1st F

G F

G F

G F

G F

G F

G F

**GROUND FLOOR (use)**

**Hard to reach**  
**Hard to control**

## REQUIREMENTS FOR EACH OF THE FLOOR'S APPLIANCES.

### F MANUAL REACH

#### F4 F5 SWITCHES

PLACED AT A HEIGHT OF MAXIMUM COMFORT  
(90 cm.) AND AWAY FROM THE CORNERS

#### F4 HANDLES

PLACED AT A HEIGHT OF MAXIMUM COMFORT (90 cm.)

#### F2 TAPS

PLACED WITHIN REACHABLE AREAS  
ON THE HORIZONTAL PLANE

#### F4 F5 PLUGS

PLACED AT A MINIMUM HEIGHT OF 40 cm. AND  
40 cm. AWAY FROM THE CORNERS

### M HANDLING CONTROL

#### M2 SWITCHES

PRESSURE ACTIVATION

#### M3 HANDLES

DOWNWARD-PRESSURE ACTIVATION

#### M5 TAPS

MIXER TYPE

Caption





**REQUIREMENTS FOR EACH OF THE FLOOR'S APPLIANCES**

- F MANUAL REACH**
- F4 F5 SWITCHES**  
PLACED AT A HEIGHT OF MAXIMUM COMFORT (90 cm.) AND AWAY FROM THE CORNERS
- F4 HANDLES**  
PLACED AT A HEIGHT OF MAXIMUM COMFORT (90cm.)
- F2 TAPS**  
PLACED WITHIN REACHABLE AREAS ON THE HORIZONTAL PLANE
- F4 F5 PLUGS**  
PLACED AT A MINIMUM HEIGHT OF 40 cm. AND 40 cm. AWAY FROM THE CORNERS
- M HANDLING CONTROL**
- M2 SWITCHES**  
PRESSURE ACTIVATION
- M3 HANDLES**  
DOWNWARD-PRESSURE ACTIVATION
- M5 TAPS**  
MIXER TYPE

G F

1st F

G F

1st F

1st F

1st F

1st F

1st F

1st F

1st F

**TYPICAL FLOOR (use)** **Hard to reach** **Hard to control**

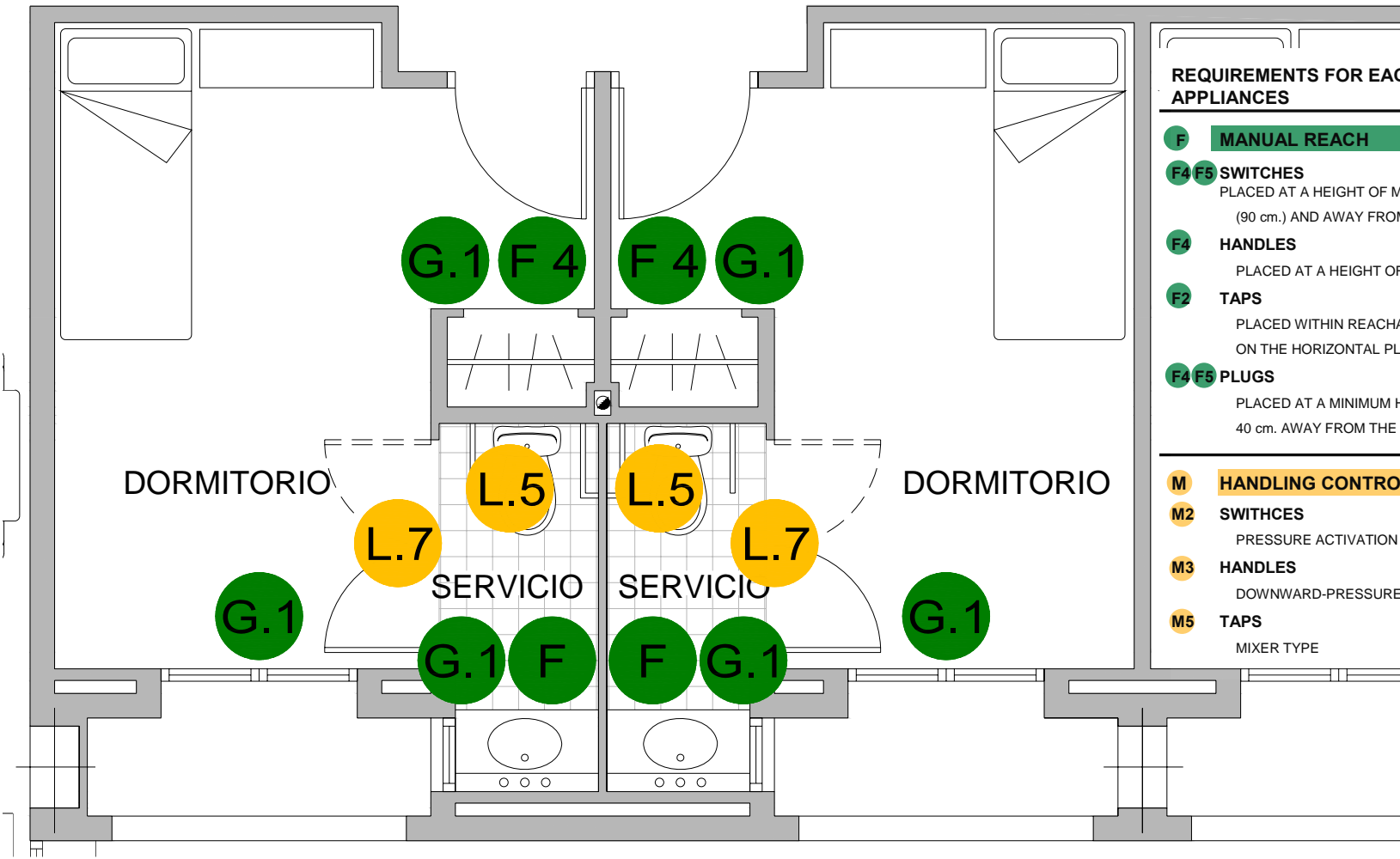

**REQUIREMENTS FOR EACH OF THE FLOOR'S APPLIANCES**

- F MANUAL REACH**
- F4 F5 SWITCHES**  
PLACED AT A HEIGHT OF MAXIMUM COMFORT (90 cm.) AND AWAY FROM THE CORNERS
- F4 HANDLES**  
PLACED AT A HEIGHT OF MAXIMUM COMFORT (90 cm.)
- F2 TAPS**  
PLACED WITHIN REACHABLE AREAS ON THE HORIZONTAL PLANE
- F4 F5 PLUGS**  
PLACED AT A MINIMUM HEIGHT OF 40 cm. AND 40 cm. AWAY FROM THE CORNERS

- M HANDLING CONTROL**
- M2 SWITCHCES**  
PRESSURE ACTIVATION
- M3 HANDLES**  
DOWNWARD-PRESSURE ACTIVATION
- M5 TAPS**  
MIXER TYPE

**BEDROOM.**      **Hard to reach**  
                          **Hard to control**

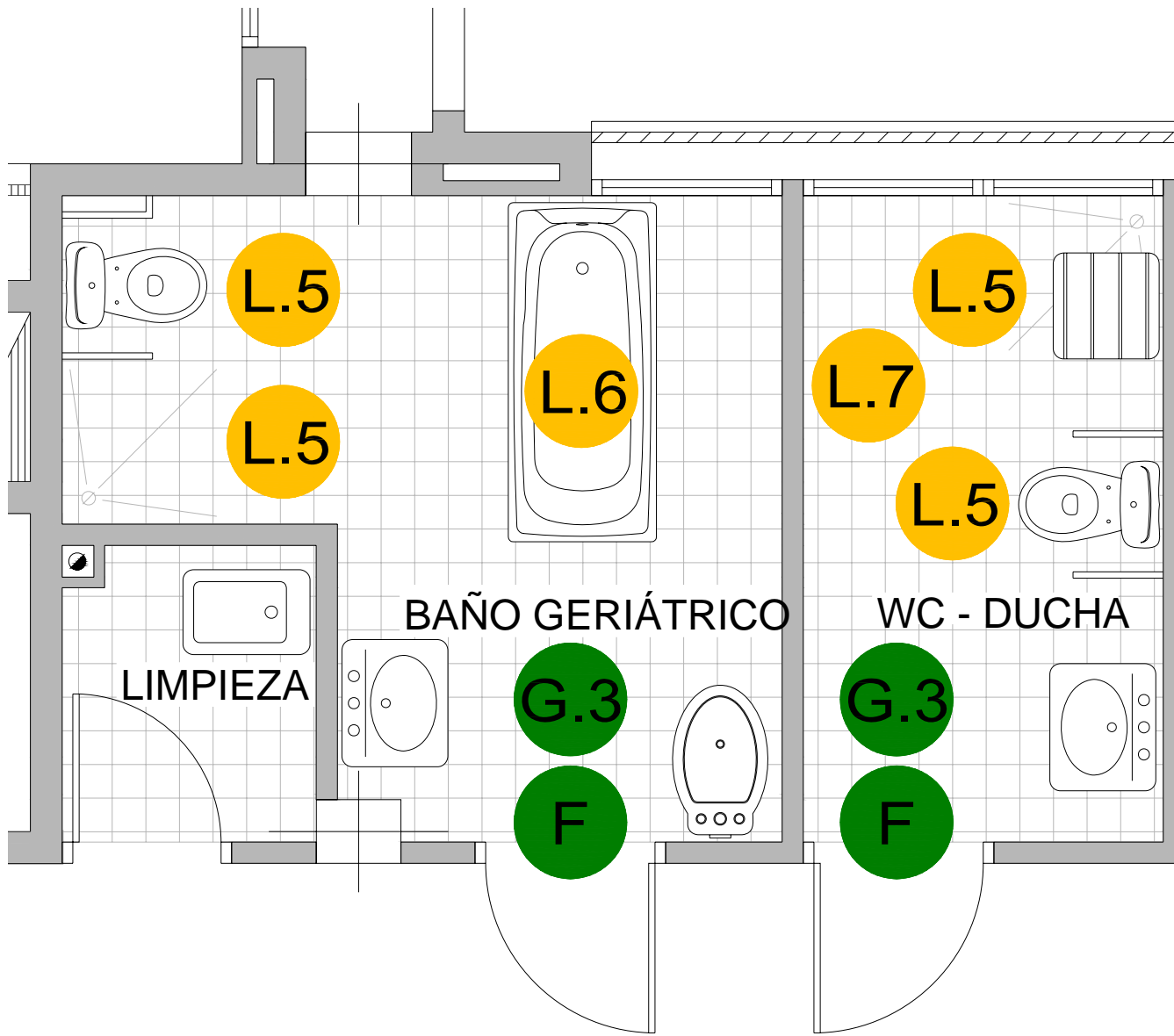

**REQUIREMENTS FOR EACH OF THE FLOOR'S APPLIANCES**

- F MANUAL REACH**
- F4 F5 SWITCHES**  
PLACED AT A HEIGHT OF MAXIMUM COMFORT (90 cm.) AND AWAY FROM THE CORNERS
- F4 HANDLES**  
PLACED AT A HEIGHT OF MAXIMUM COMFORT (90 cm.)
- F2 TAPS**  
PLACED WITHIN REACHABLE AREAS ON THE HORIZONTAL PLANE
- F4 F5 PLUGS**  
PLACED AT A MINIMUM HEIGHT OF 40 cm. AND 40 cm. AWAY FROM THE CORNERS

- M HANDLING CONTROL**
- M2 SWITCHES**  
PRESSURE ACTIVATION
- M3 HANDLES**  
DOWNWARD-PRESSURE ACTIVATION
- M5 TAPS**  
MIXER TYPE

**SANITARY FACILITIES.**

**Hard to reach**  
**Hard to control**

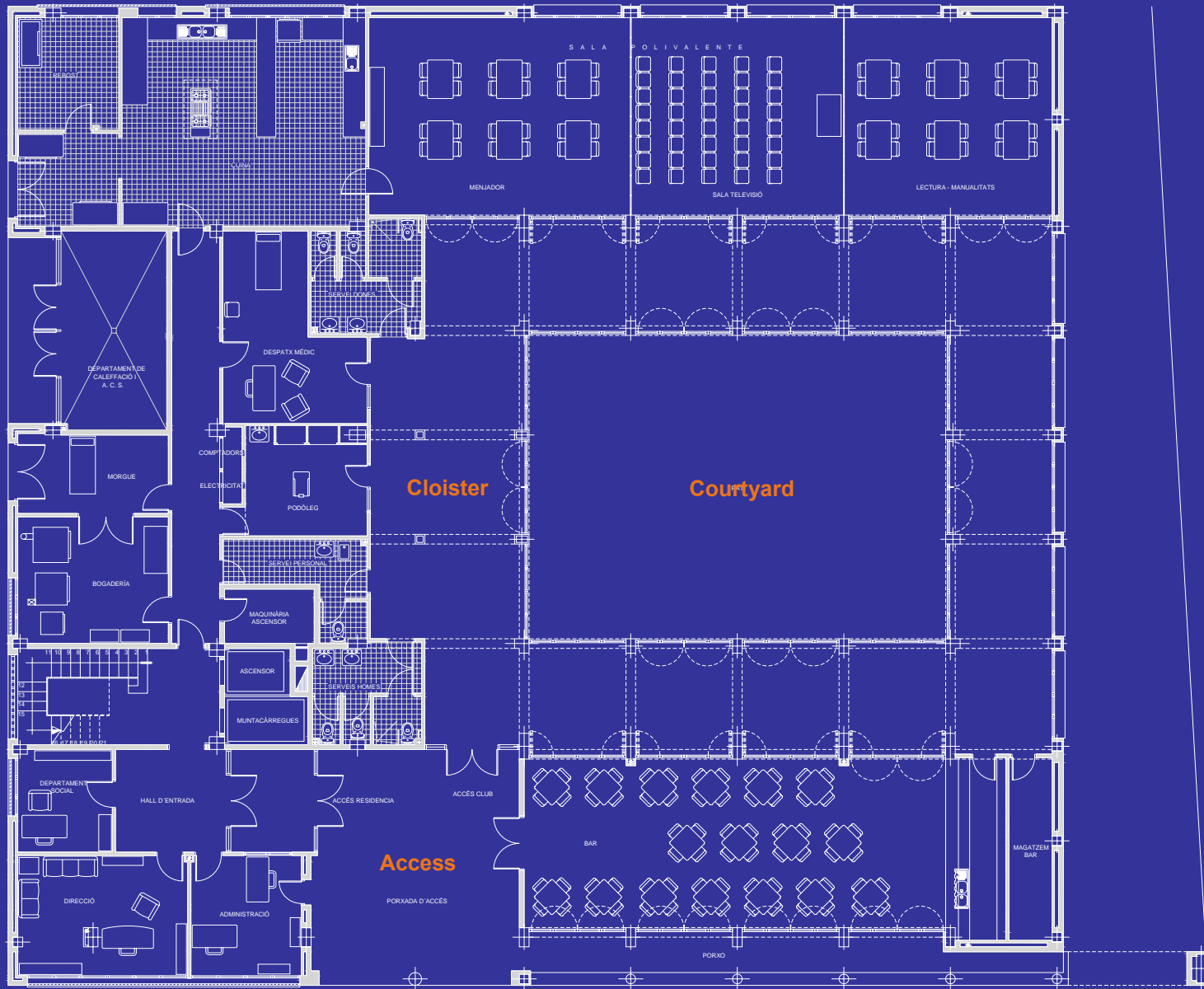

- G F
- 1st F
- G F
- 1st F

# GROUND FLOOR



Access points





Cloister. Common area

# General view



Courtyard Access



G F

1st F

G F

1st F

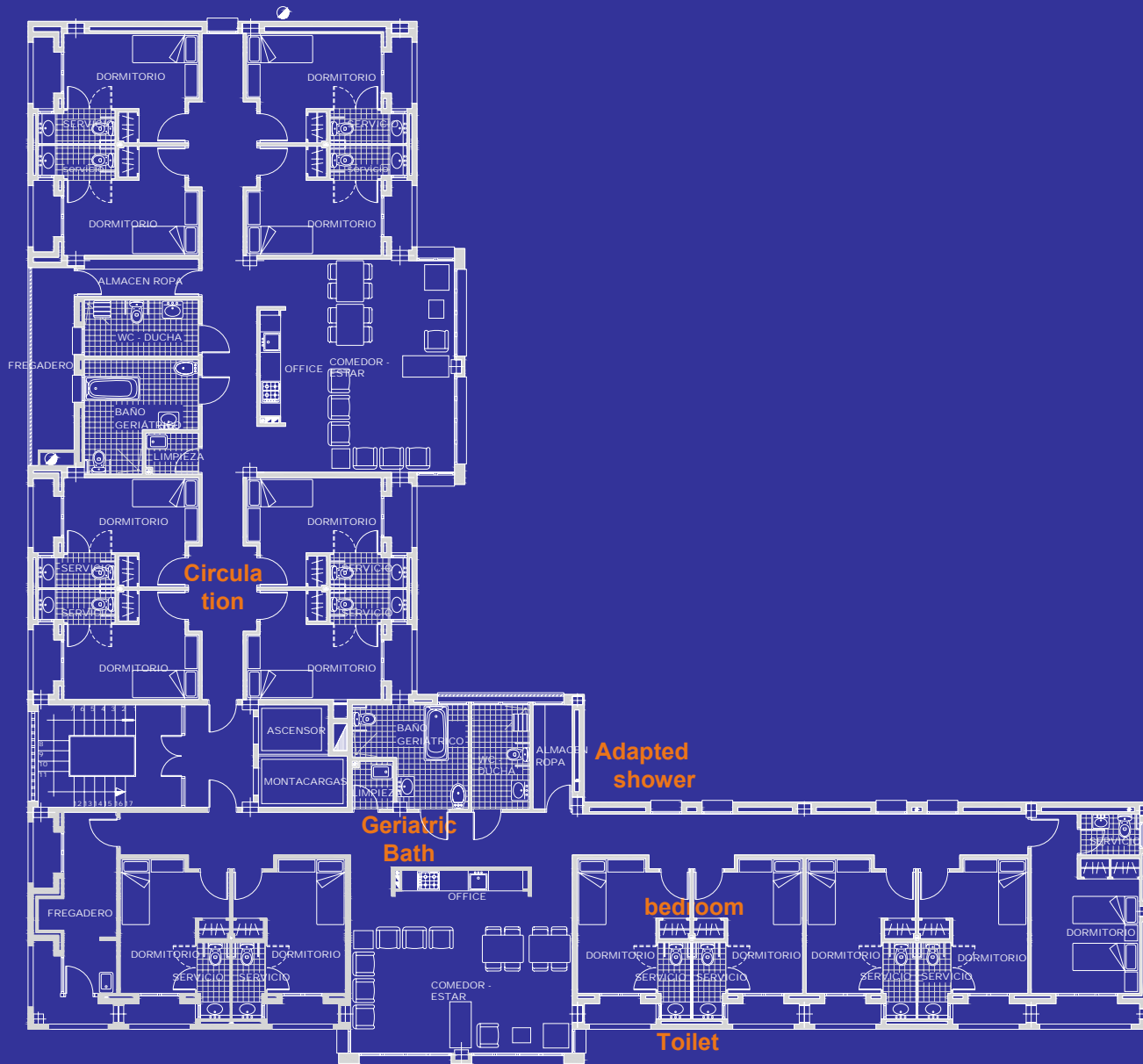

# TYPICAL FLOOR



Bedroom toilet

# Bedroom

user elements

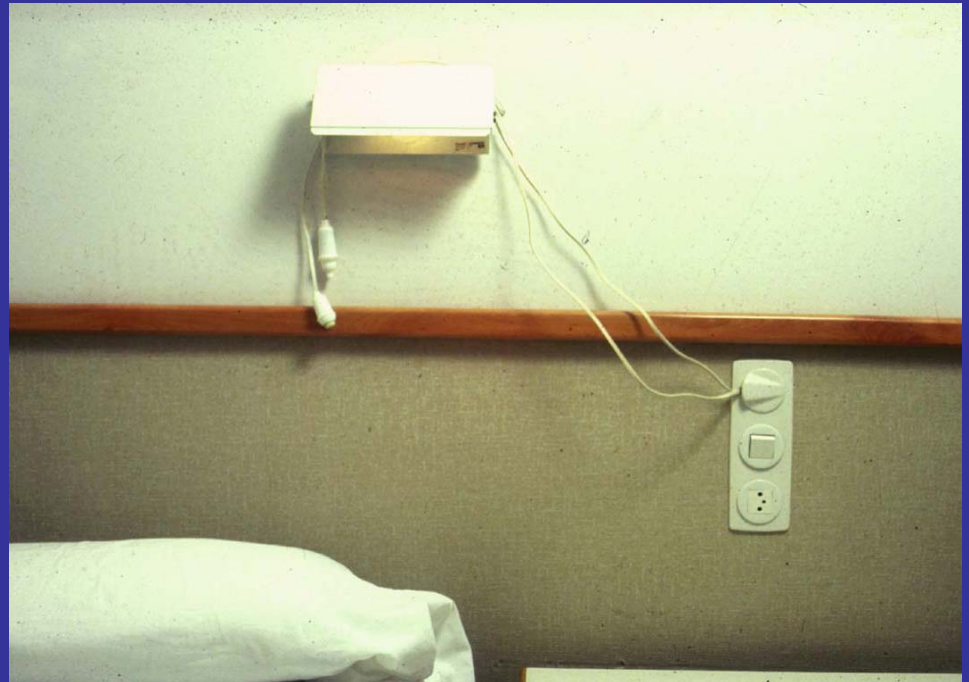

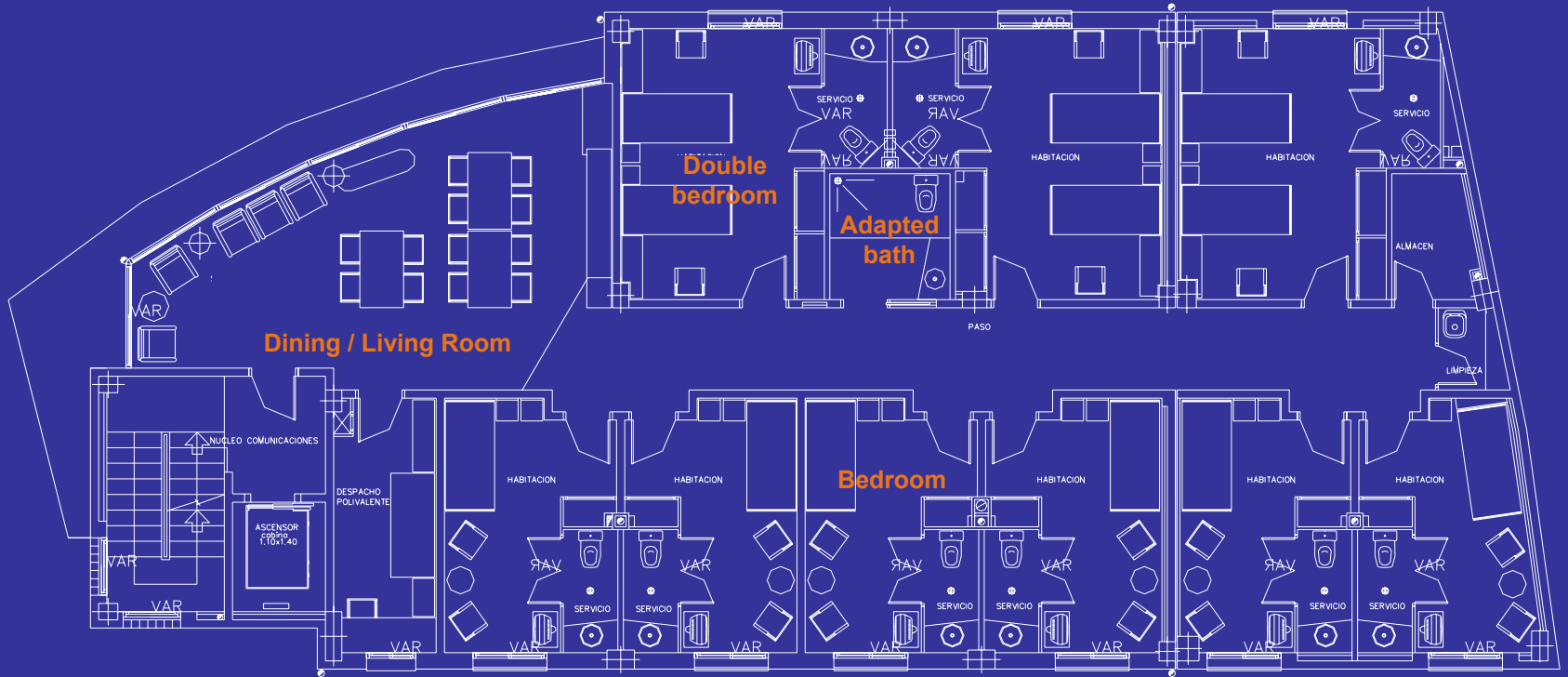

**First and second floor**



Individual bedroom

Toilet





Individual  
bedroom



Position  
of the  
bed



Individual  
bedroom



Accessibility  
to the toilet





# Llar de l'Ancianitat

Terrassa

Renovation: 1989-2002

Places: 140 residential · 30 day-centre

Owned by: Fundació Privada President Torres Falguera



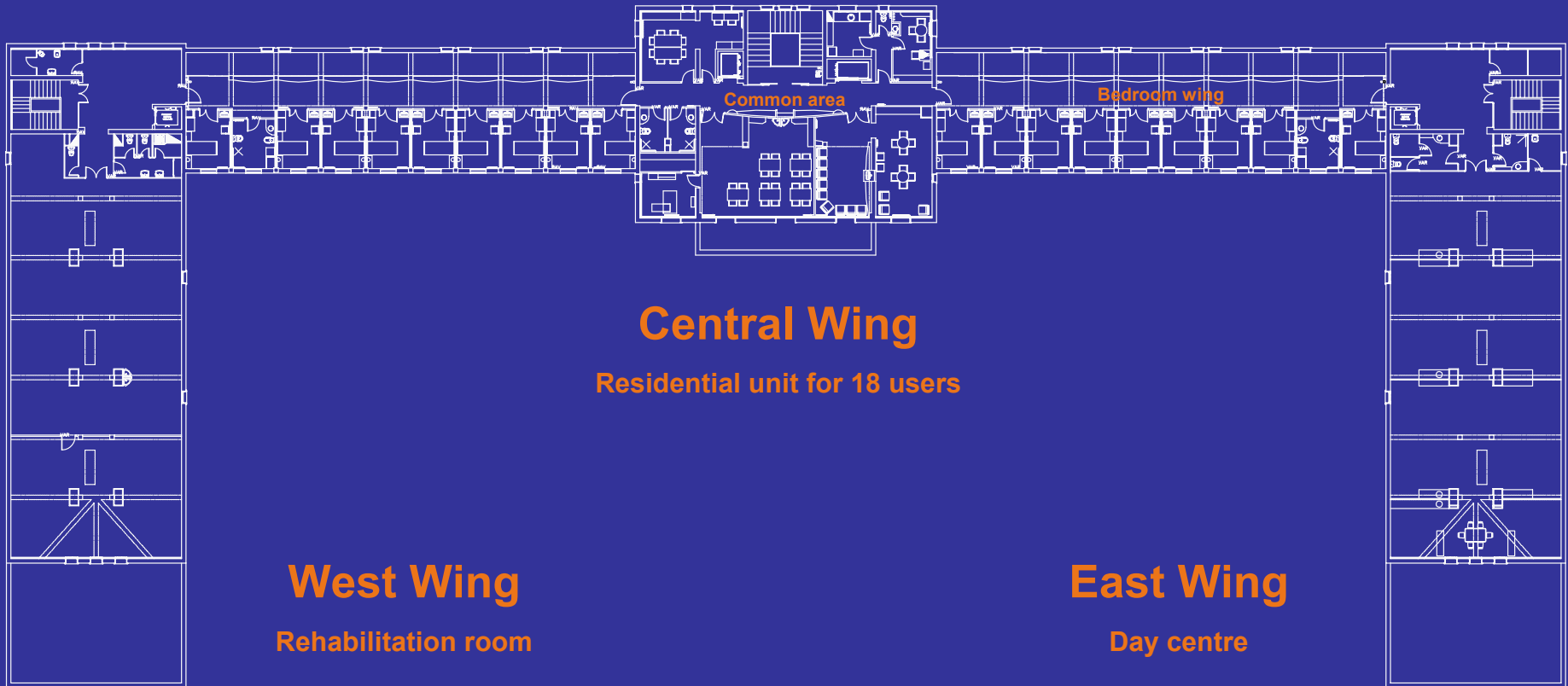

# Second Floor

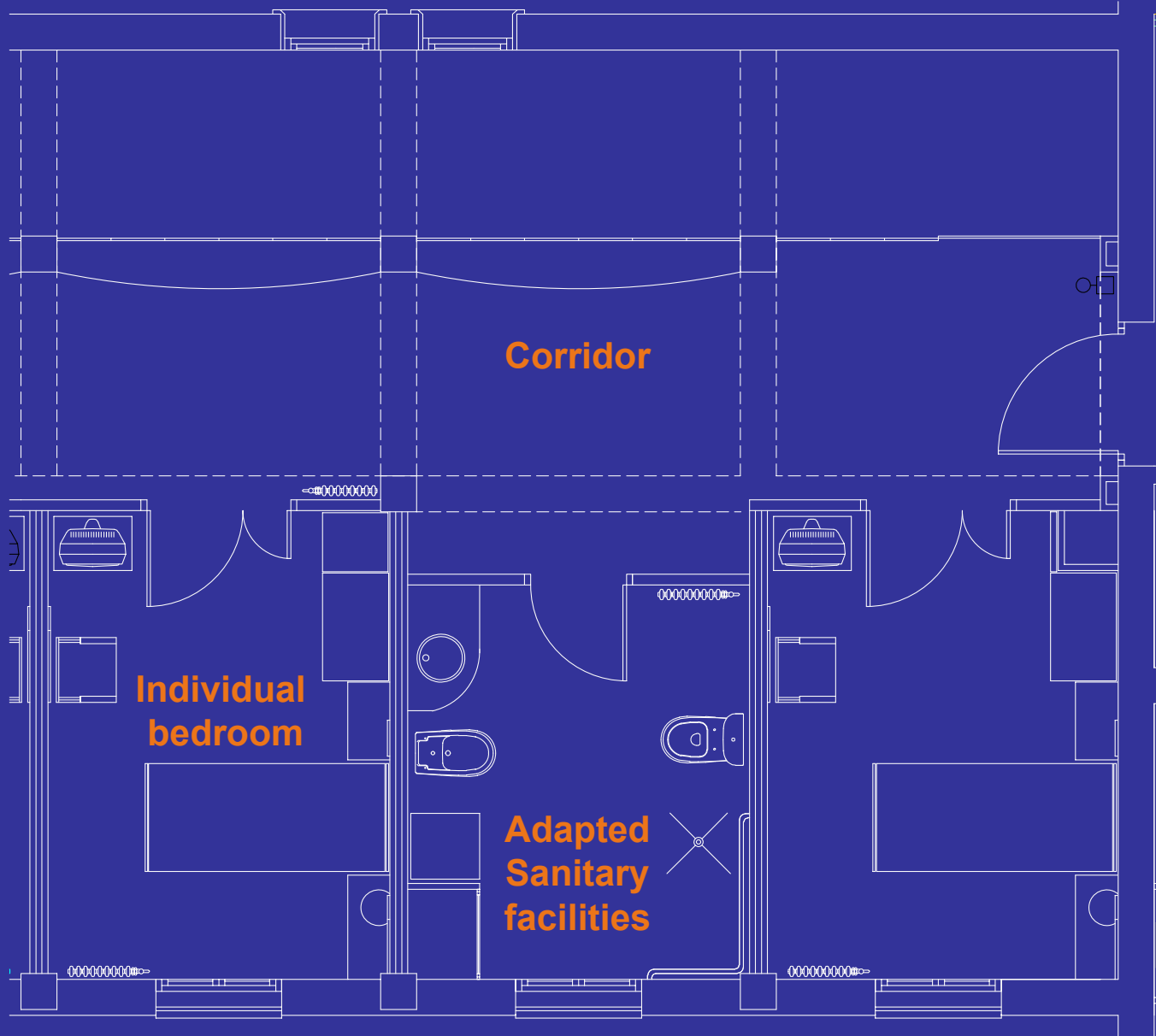

# Bedroom wing



Corridor and bedroom for renovation



Bedroom-wing corridor



Bedroom-wing corridor





Main access



# Adapted sanitary facilities





Rehabilitation room

# 1.-A general reflection on ...

People's relations with their physical environments:

- What kinds of problems arise?
- What alternatives does architecture offer

# 2.-Boundaries based on ...

User types:

- walkers, wheel-chair users, sensory handicaps

Types of difficulties:

- manoeuvring, changing levels, reaching, controlling

Accessibility level:

- adapted, practicable, convertible

# 3.-Precision in ...

Reference parameters

# 4.-Examples of application ...

Old-age people's homes : "Trinitat" and "Llar Ancianitat"

# 5.-Appendix: Technologies for accessibility

"Active" technologies in improving personal autonomy at home